

Farmmodels.nl

Landbouwminiaturen ~ Onderdelen ~ Bouwkitjes ~ Stickers ~ Dioramabouw

Jan Veenhuis Landbouwkipper JVLK 19000

bouw handleiding



Beste modelbouwer,

bedankt voor de aanschaf van een Farmmodels bouwpakket.

U heeft hier de gedetailleerde beschrijving van uw bouwkit in schaal 1:32
In fases wordt stap voor stap uitgelegd hoe u alle onderdelen samenstelt.

Lees eerst alle fases goed door, voordat u begint.

Het meeste freeswerk zit in de plaat vast met "bridges", dat zijn kleine stukjes om de gefreesde onderdelen in de plaat vast te houden.

Snij door deze bridges heen om de onderdelen los te maken.

Schoon daarna waar nodig het freeswerk op, verwijder eventuele resten en vijl alle scherpe hoeken / randen wat af.

Dat bevordert later het spuitwerk...

In deze beschrijving is niet aangegeven wanneer u het beste onderdelen van kleur / verf kunt voorzien, daar dit afhankelijk is van de door u gekozen kleurstelling. Hou daar zelf rekening mee tijdens de bouw.

Belangrijk is de juiste soort lijm te gebruiken.

Wij adviseren 2 soorten lijm:

Modelbouwlijm voor polysyreen (plastic / kunststof is Revell Contacta en secundelijm / industrie lijm.

Gedurende de bouw wordt verteld met welke lijm gewerkt dient te worden.

Deze handleiding is zo goed mogelijk samengesteld.

Mocht u derhalve toch vragen hebben, of punten opmerken ter verbetering van de handleiding, kunt u ons mailen op info@farmmodels.nl.

Wij wensen u veel "modelbouw" plezier met het samenstellen van dit model.

Met vriendelijke groet,
Team Farmmodels.nl

Benodigheden voor de bouw:

Voor de bouw van onze kitjes is het makkelijk om over het volgende gereedschap te beschikken:

* Revell mes of Stanley mes



* Vijl en schuurpapier



* Pincet



* Zijkniptang



* Punt tang



* diverse (staal) boortjes



• Lijm

○ Modelbouwlijm,



Advies: Revell Vloeibare plasticlijm.

Deze lijm droogt niet direct en geeft de mogelijkheid om delen te positioneren.

○ Secondelijm



Advies: Farmmodels super lijm.

Deze lijm droogt direct zodat delen niet lang vastgehouden hoeven te worden.

Gedurende de bouw wordt aangegeven welke lijm het meest geschikt is.



992K 19000

1: **start**

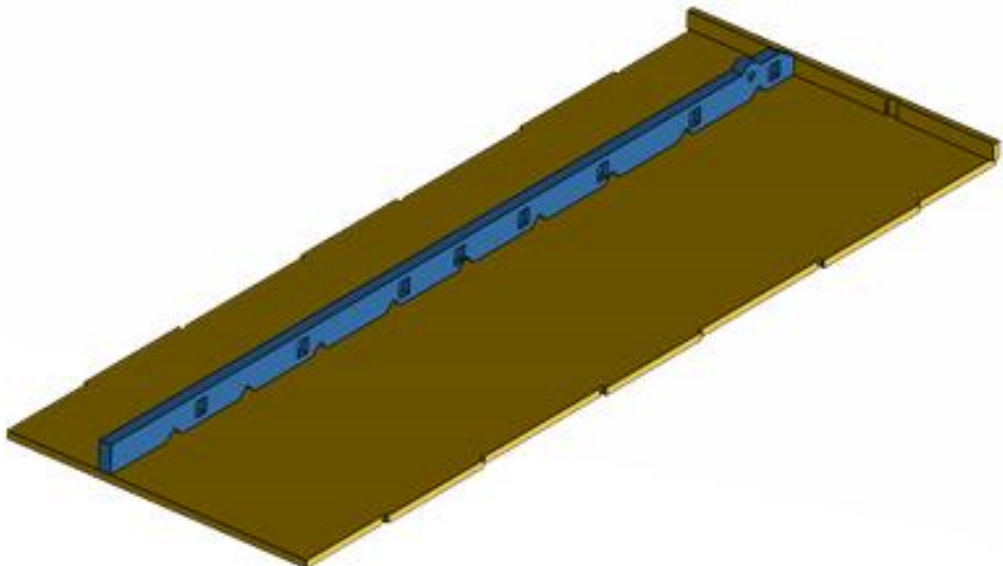
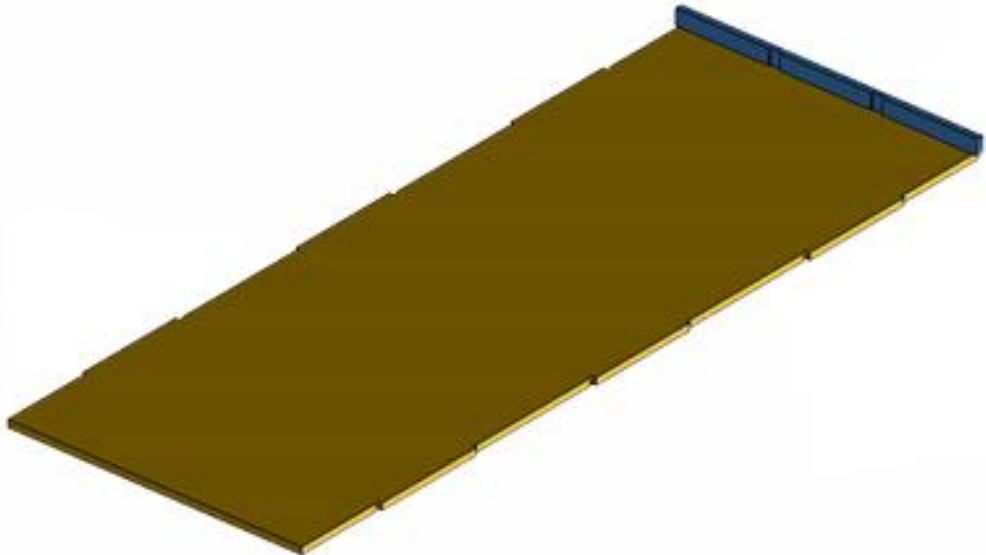
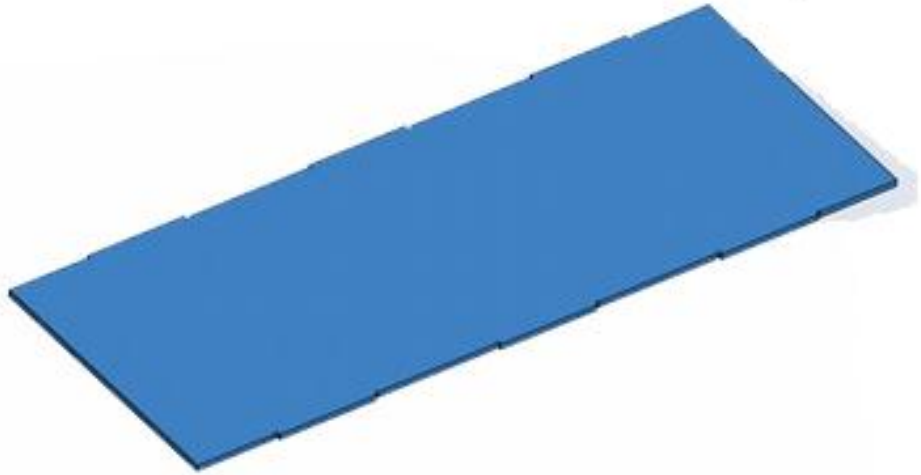



992K 19000

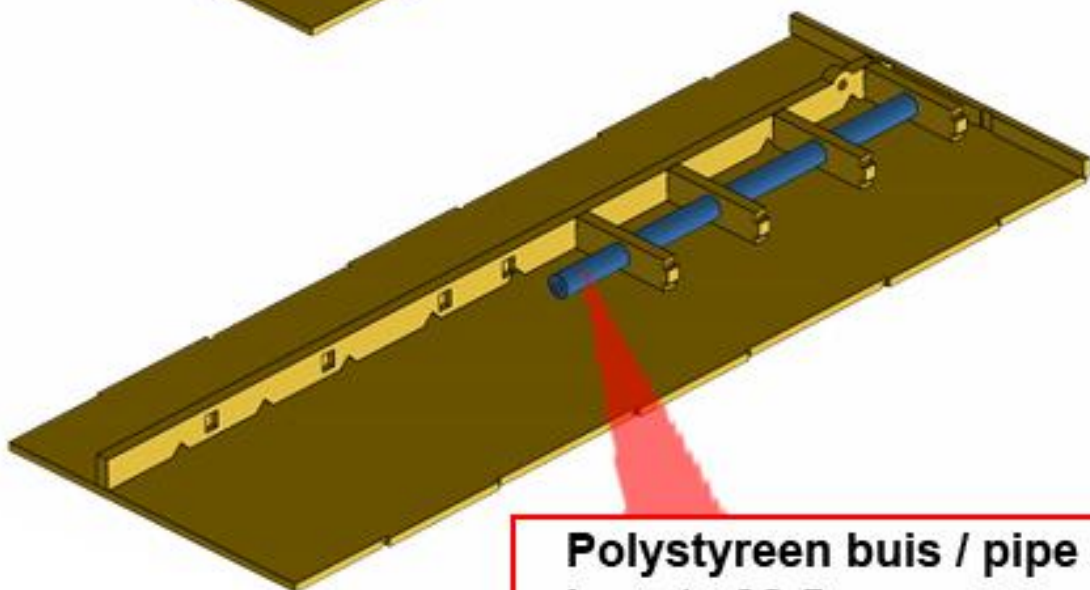
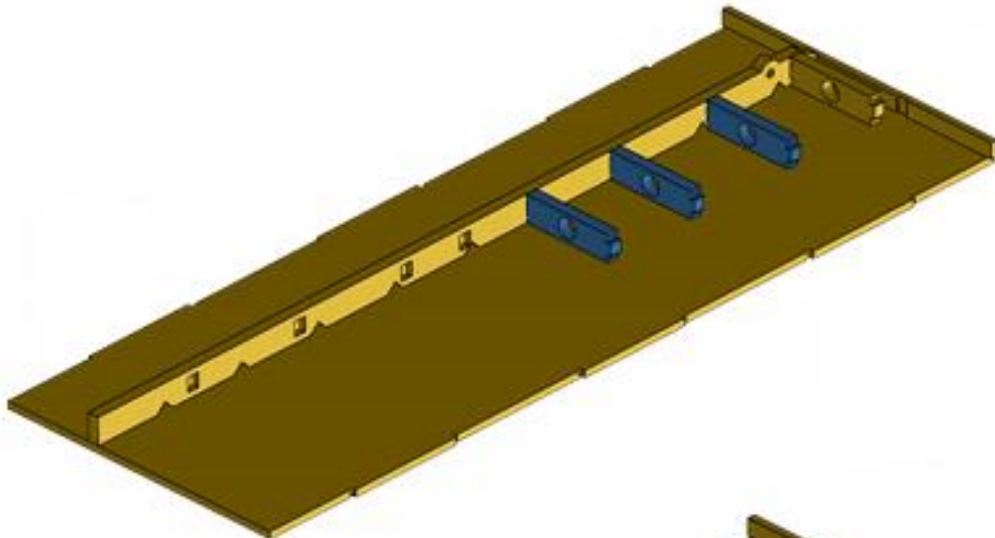
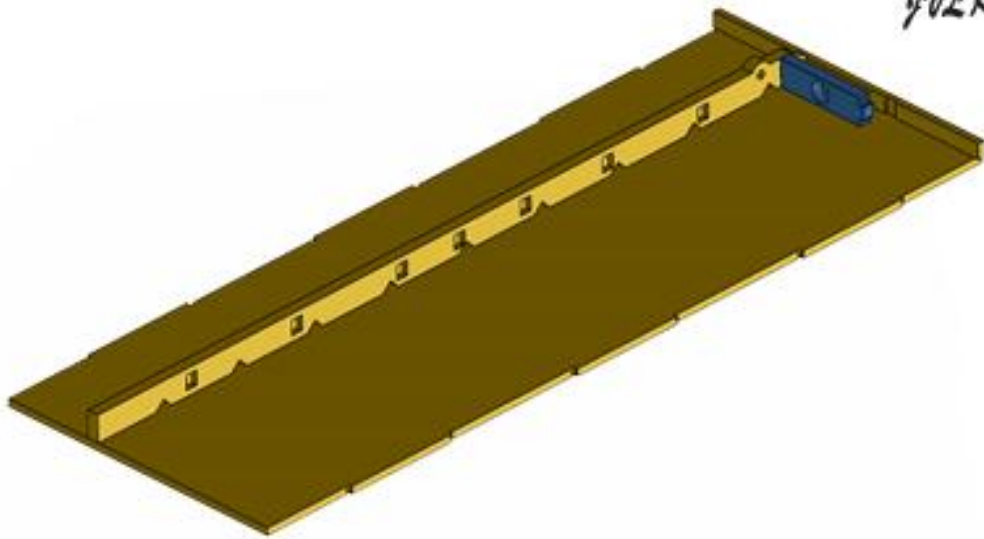

Polystyreen buis / pipe
Lengte 98.5 mm
Ø 5 mm
Lengte 98.5 mm



902K 19000

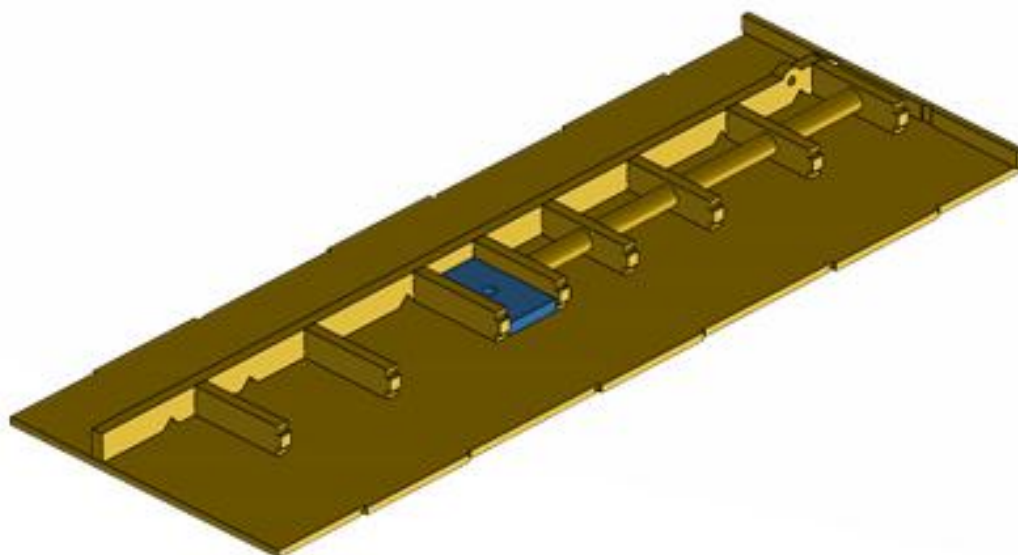
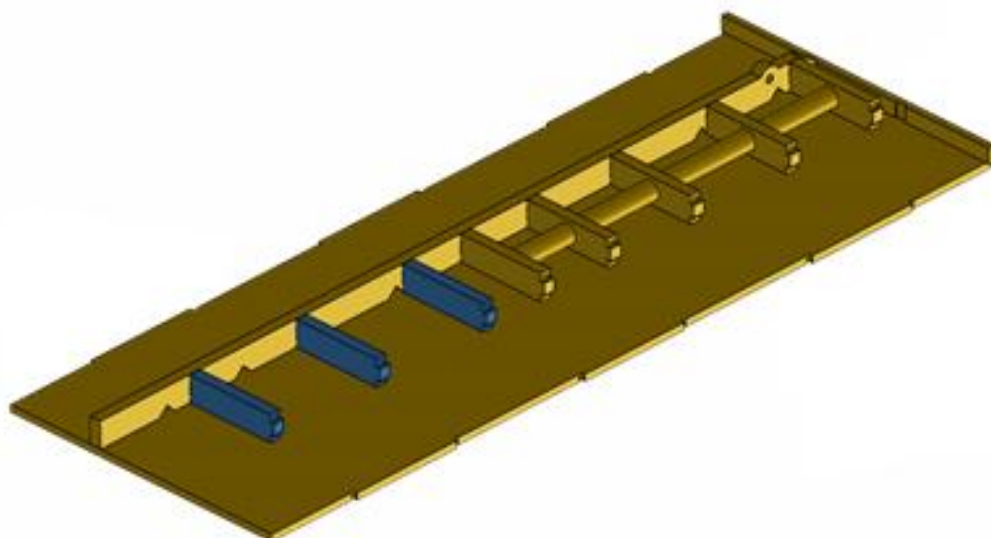
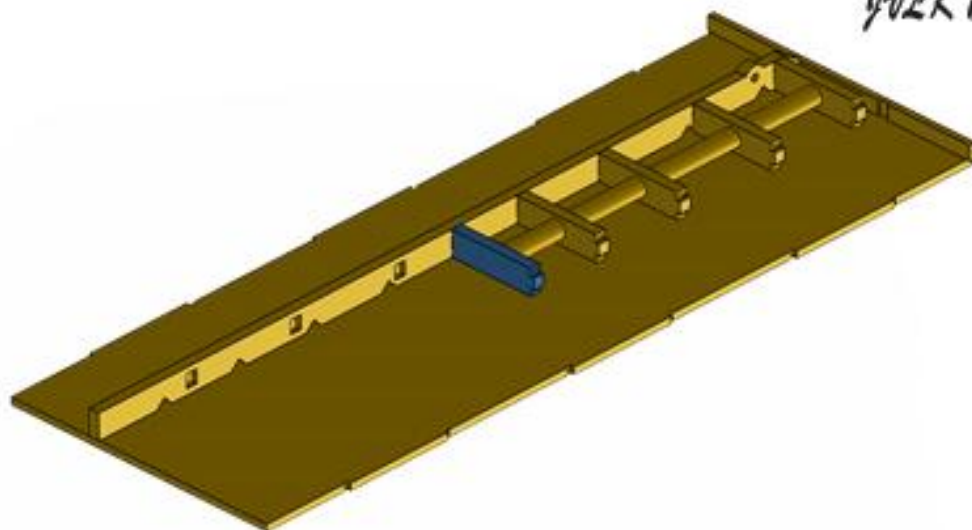



9927 19000



10:

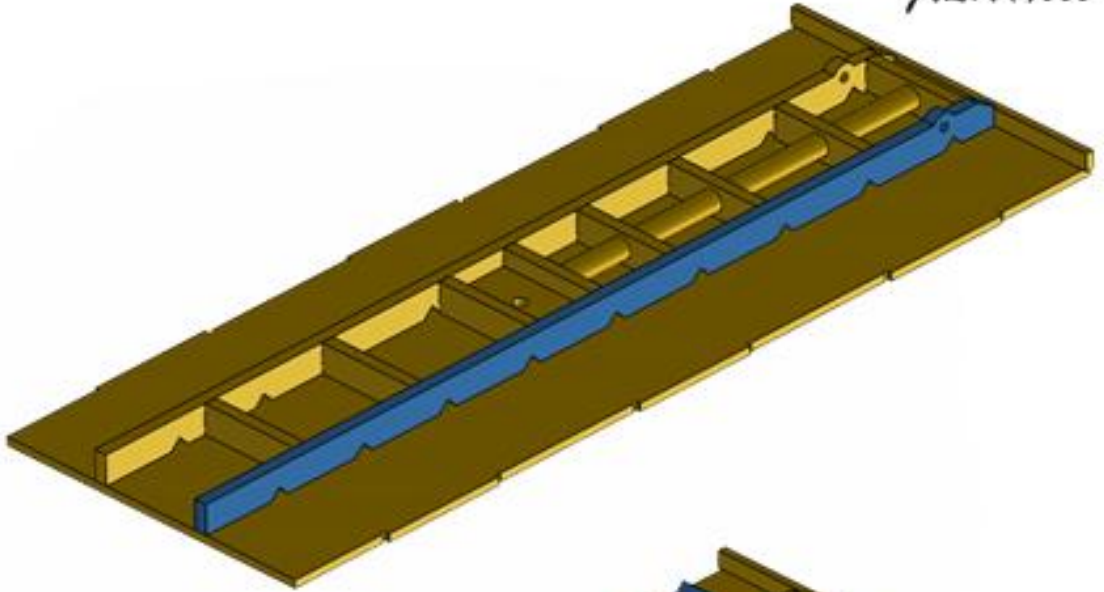

11:

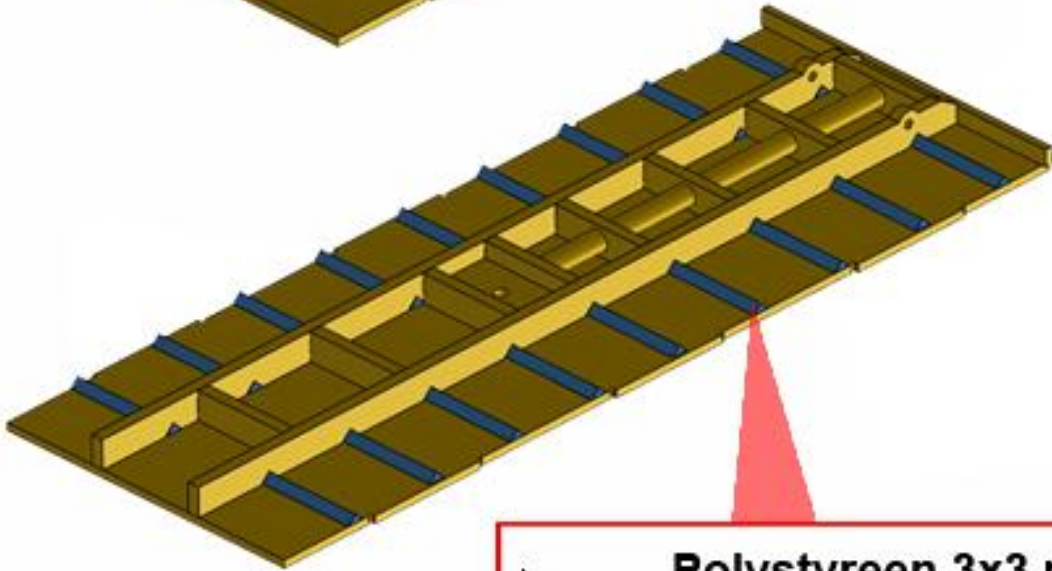

Polystyreen 3x3 mm
Lengte 27 mm
Lengtes 27 mm

12:

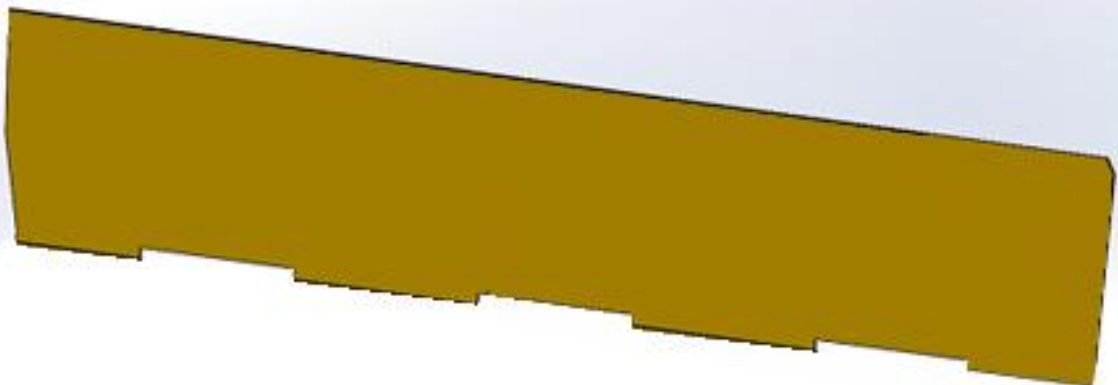



992K 19000

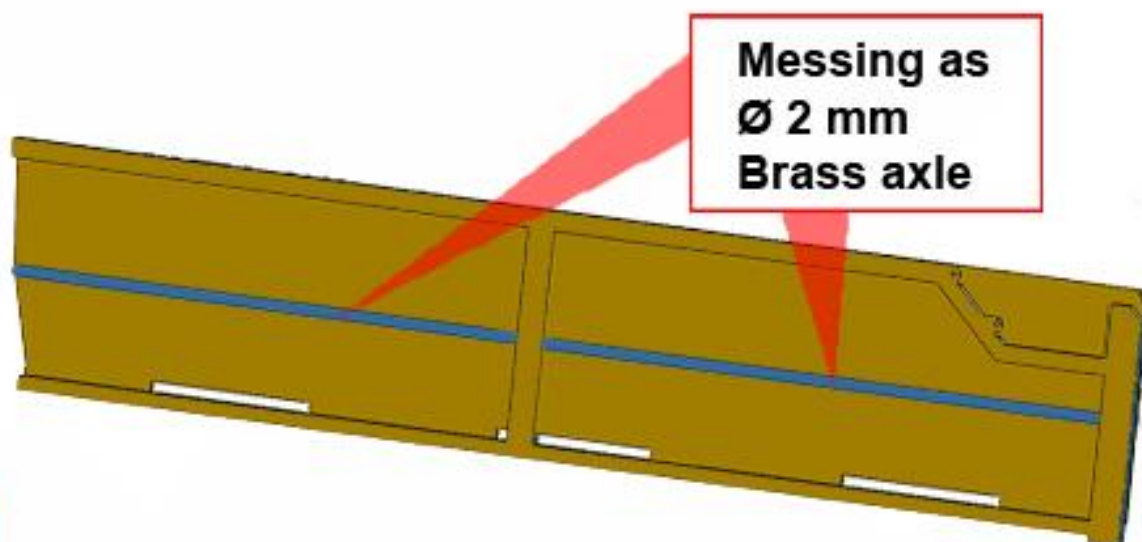
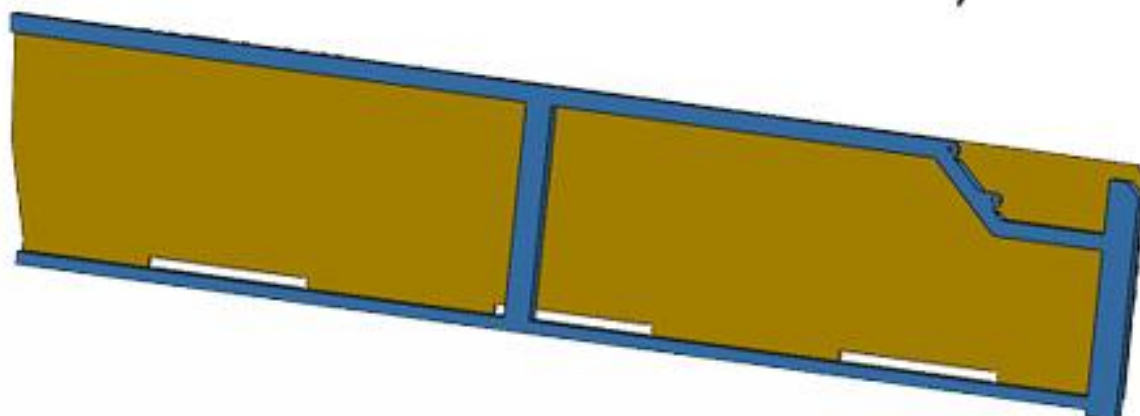

Plaats de messing as exact in het midden
Place the Brass axle exactly in the middle

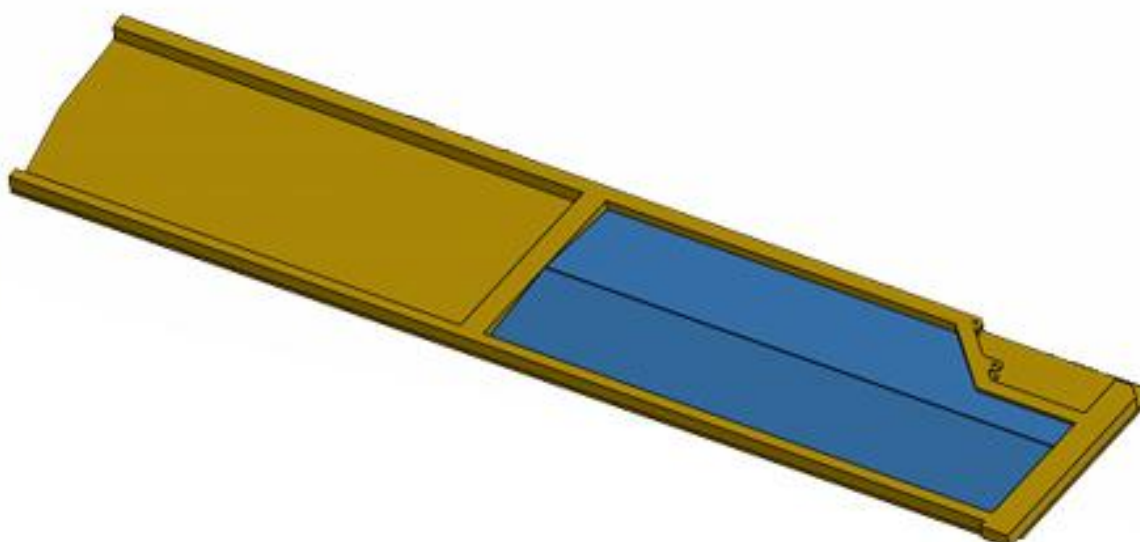



992K 19000

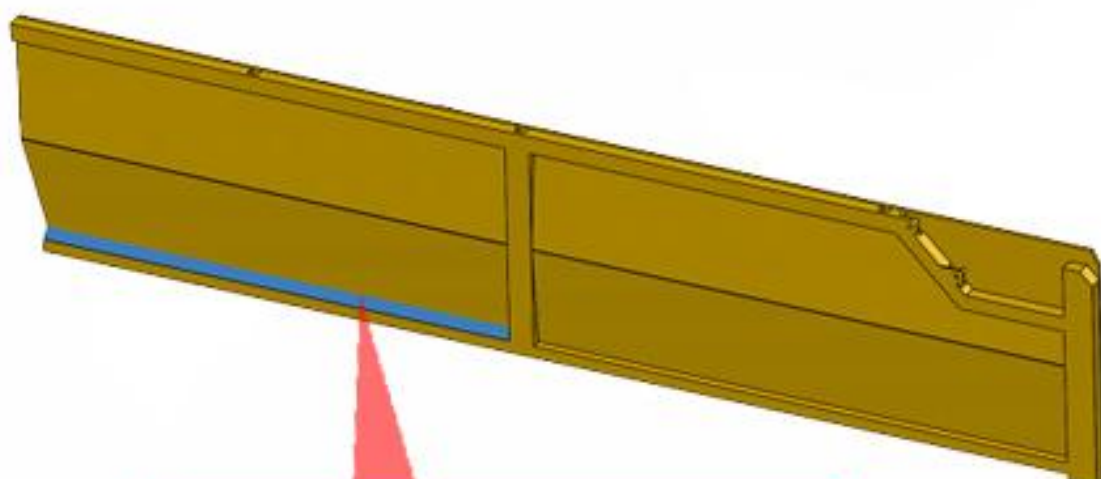
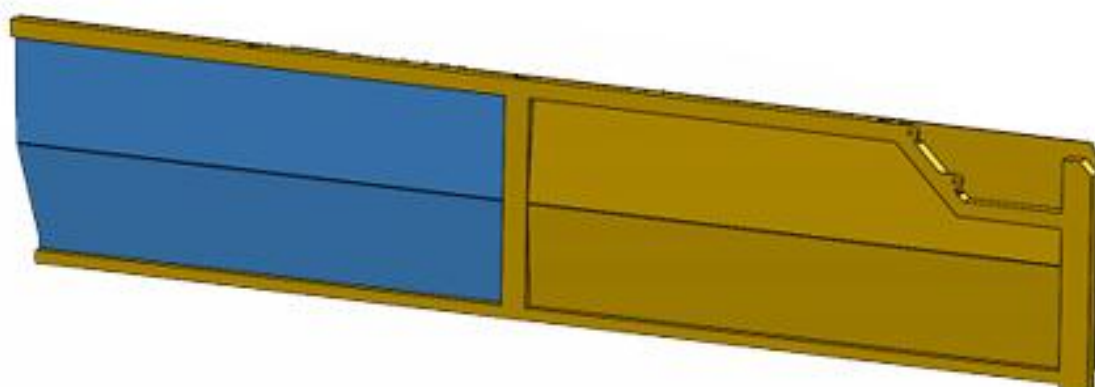

Polystyreen 2x2 mm

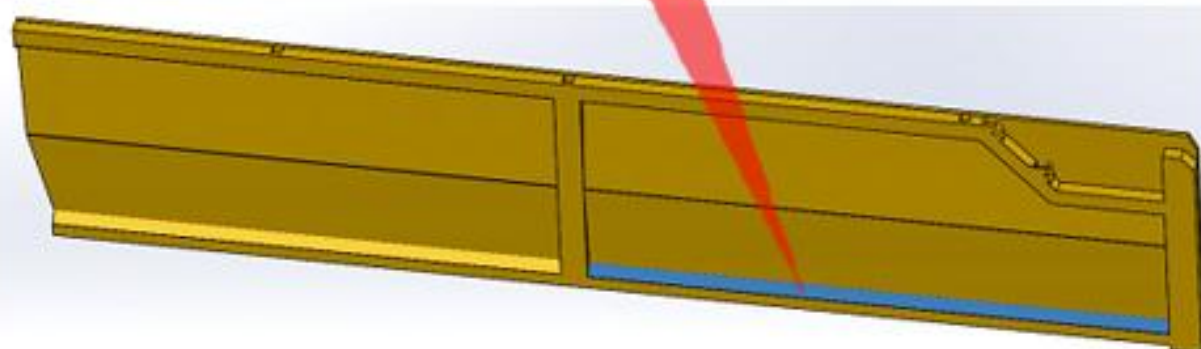



902K 19000



19:

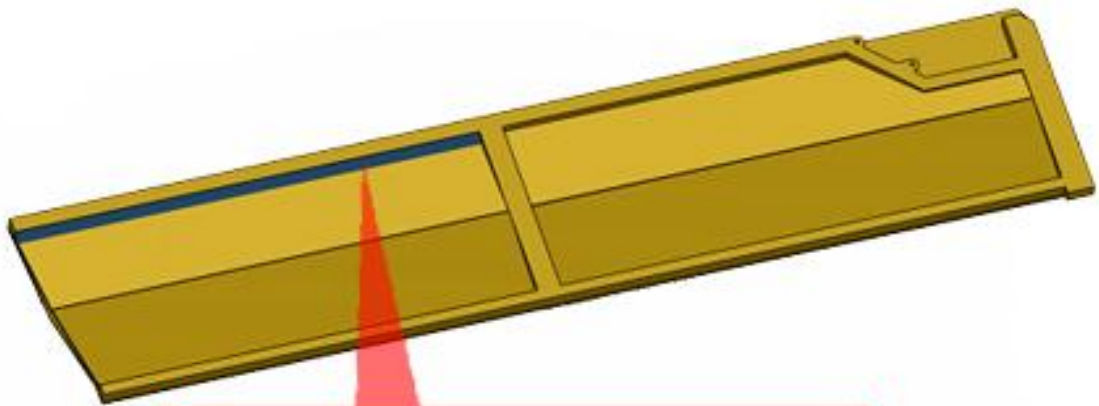

Polystyreen 2x2 mm



20:

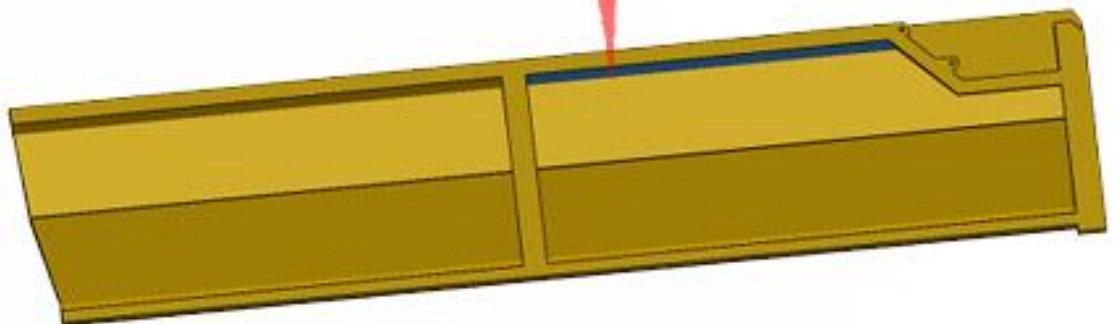

Maak dit onderdeel nu in spiegelbeeld...
Now make this part again mirror imaged..



21:

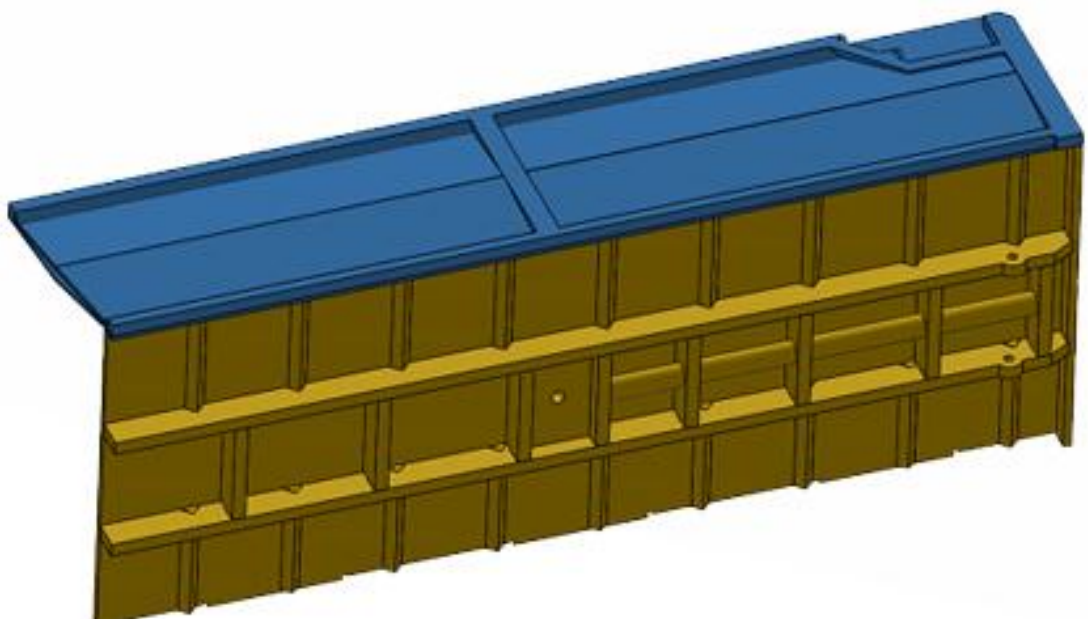



9927 19000

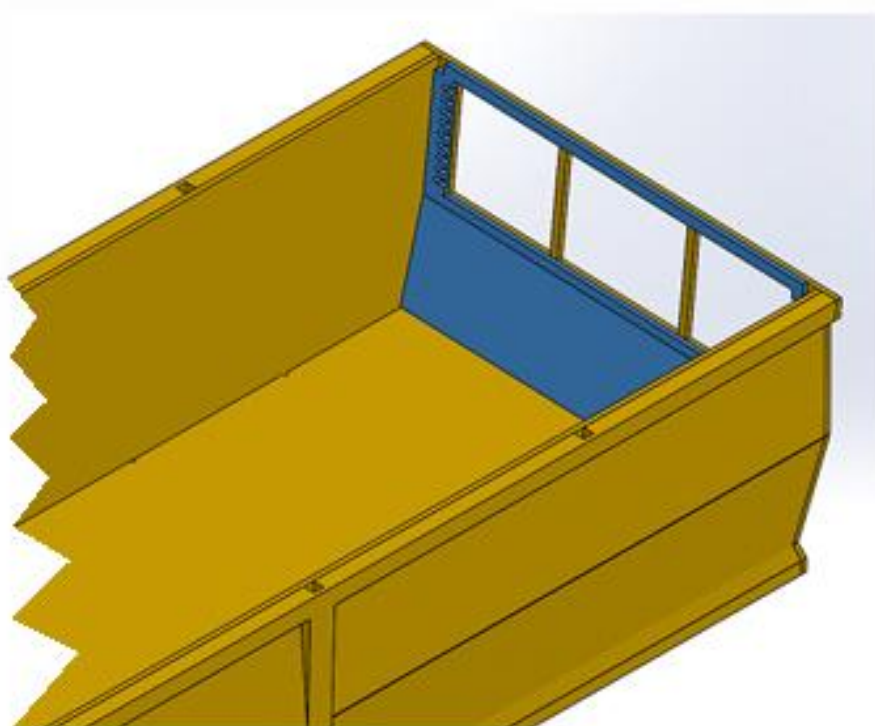
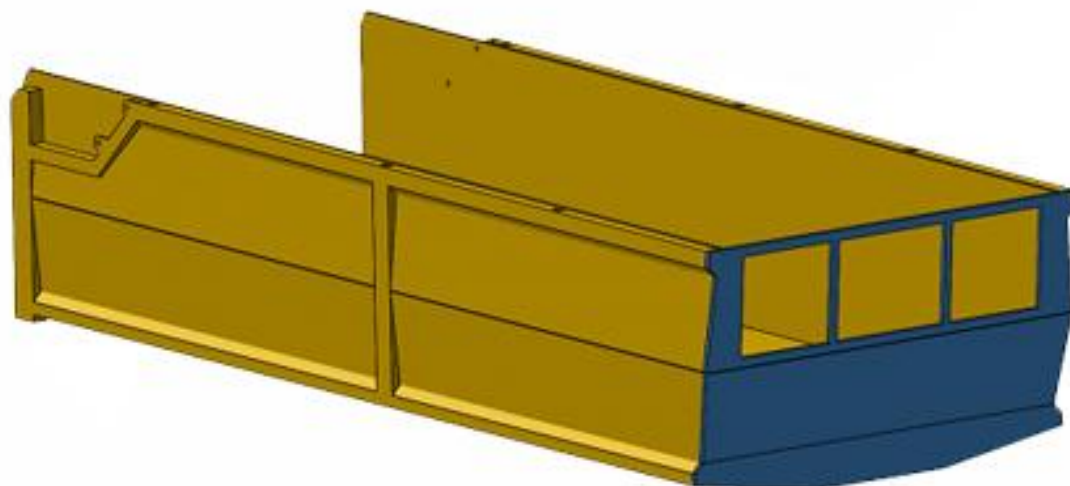
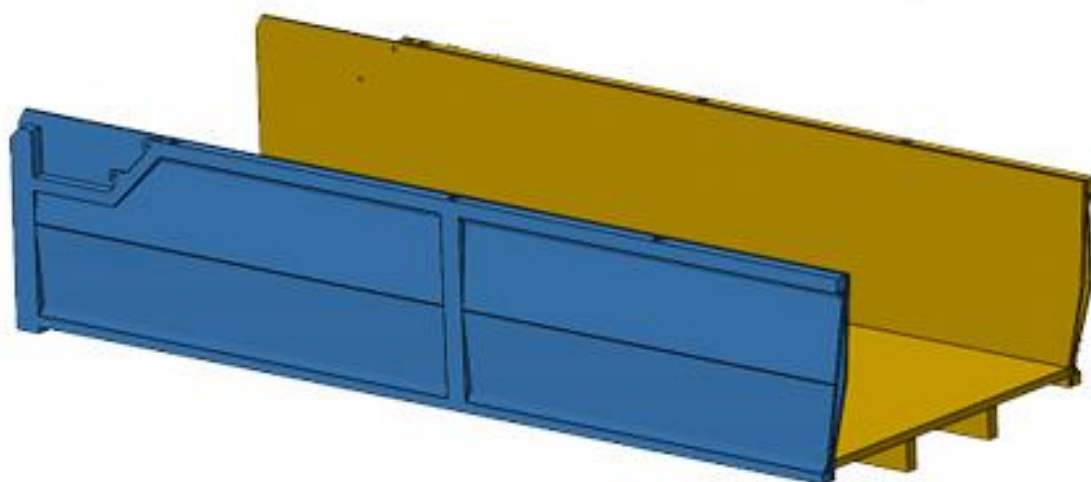



992K 19000

25:



IJzerdraad
Ø 0.95 mm
Iron Wire

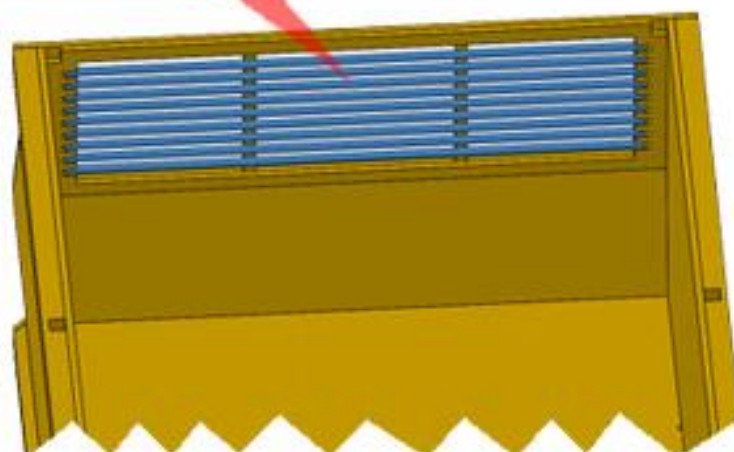

26:

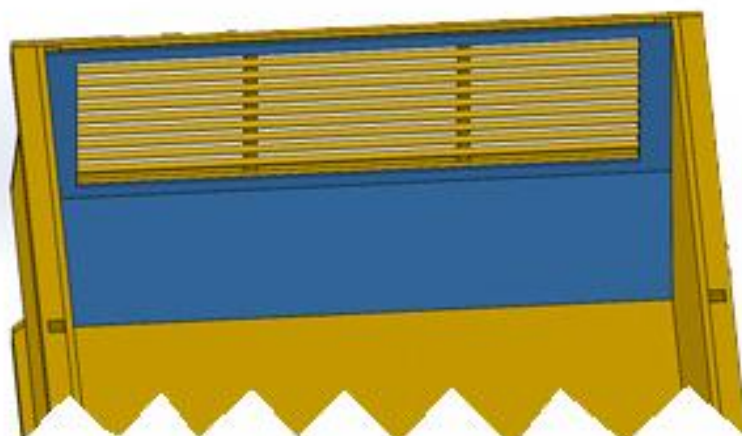

27:



Polystyreen
4x4 mm

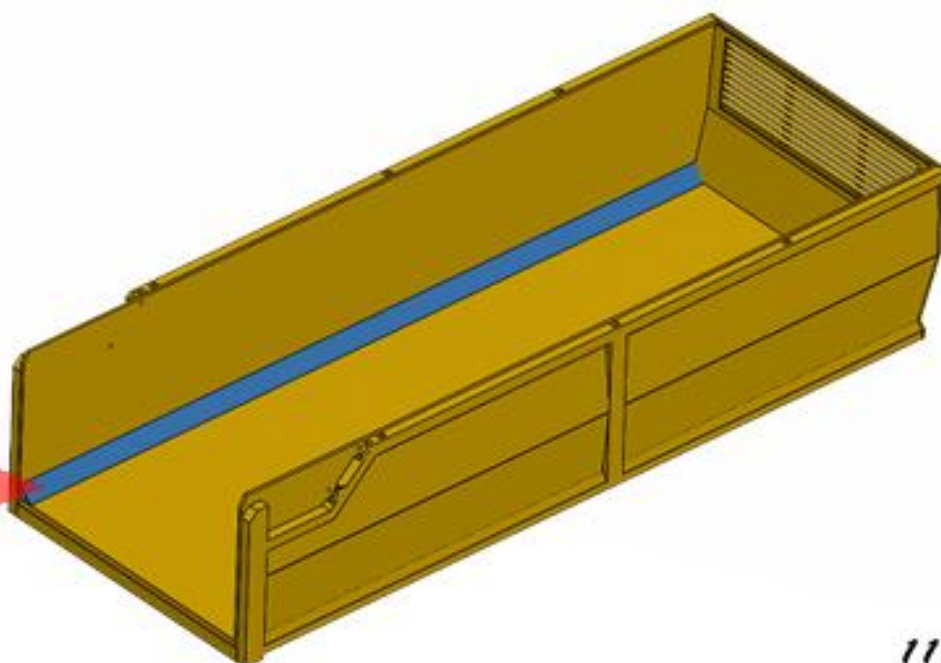



9927 19000

37:

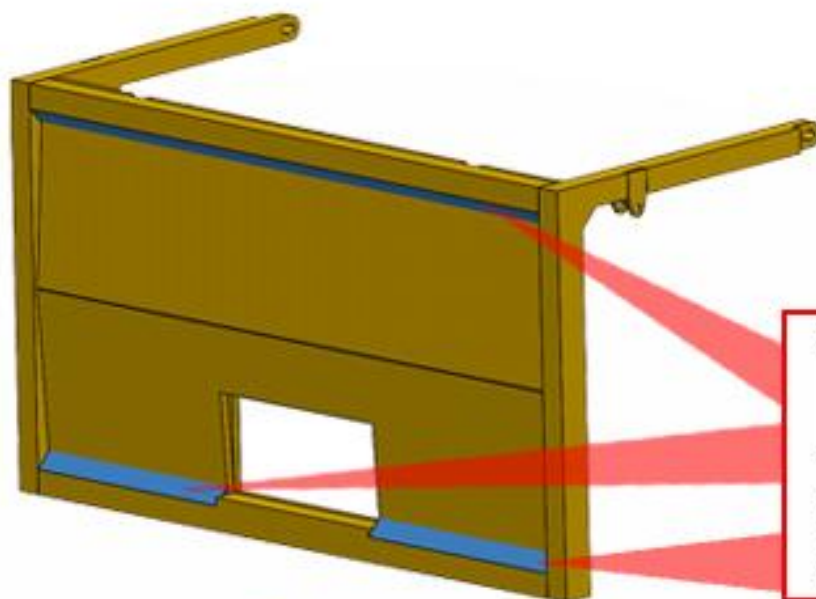

38:

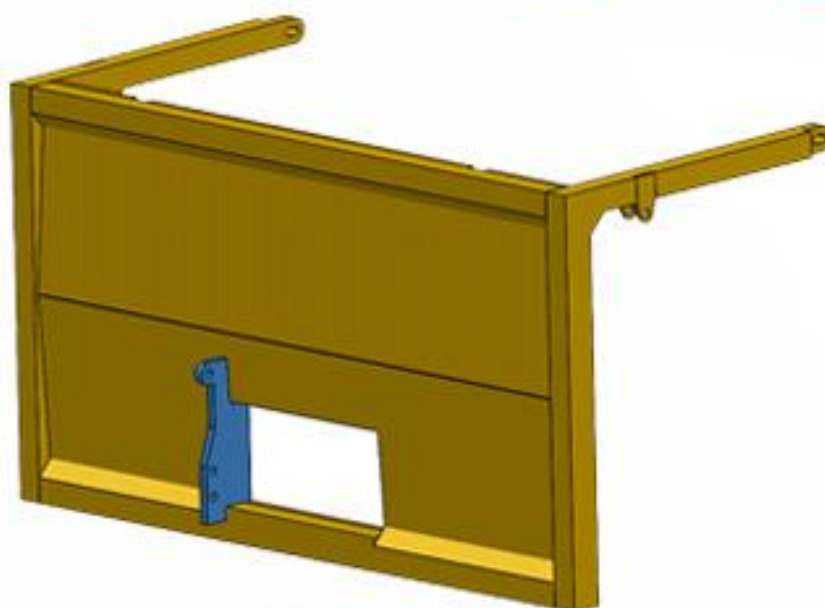

39:

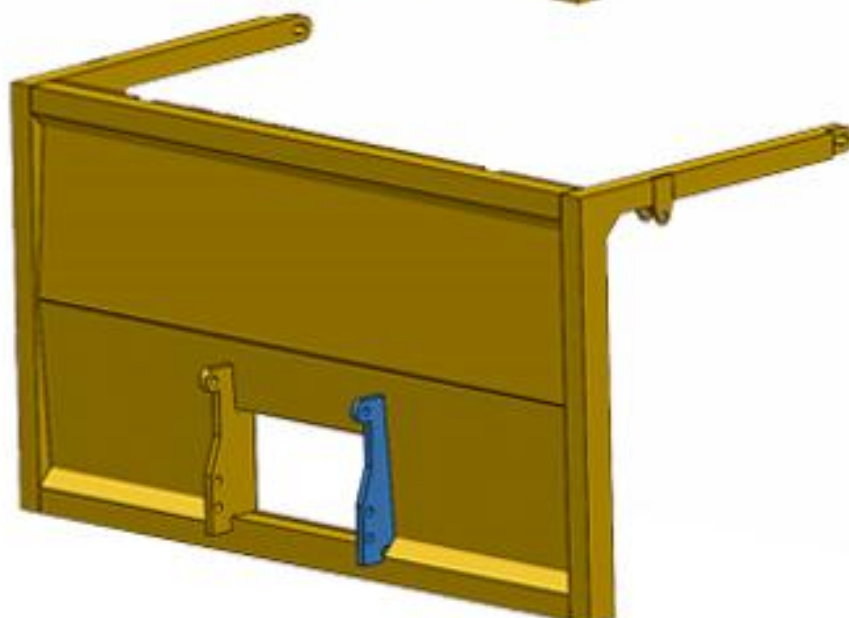



992K 19000

31:

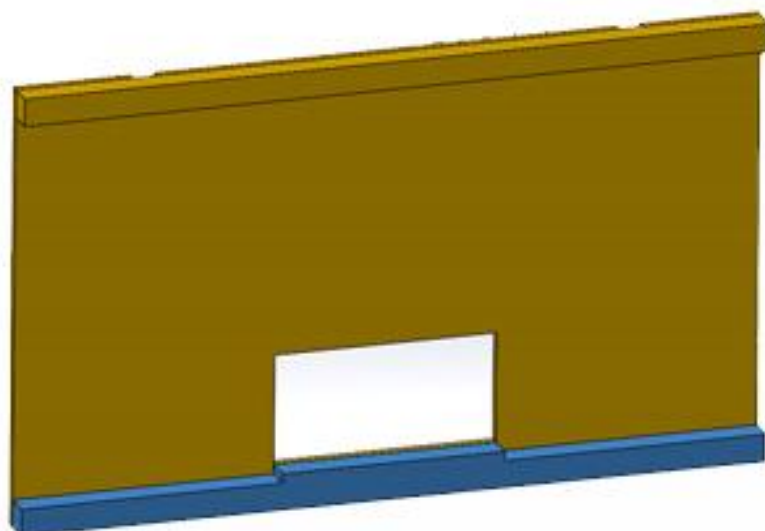

32:

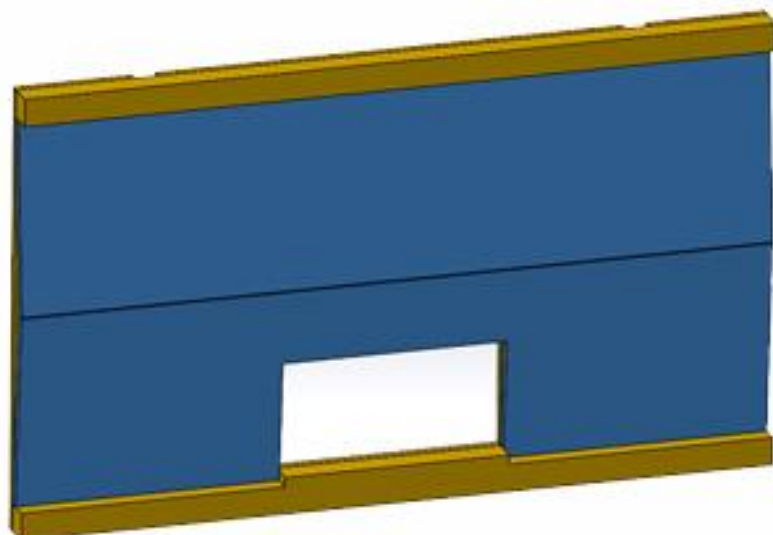

33:

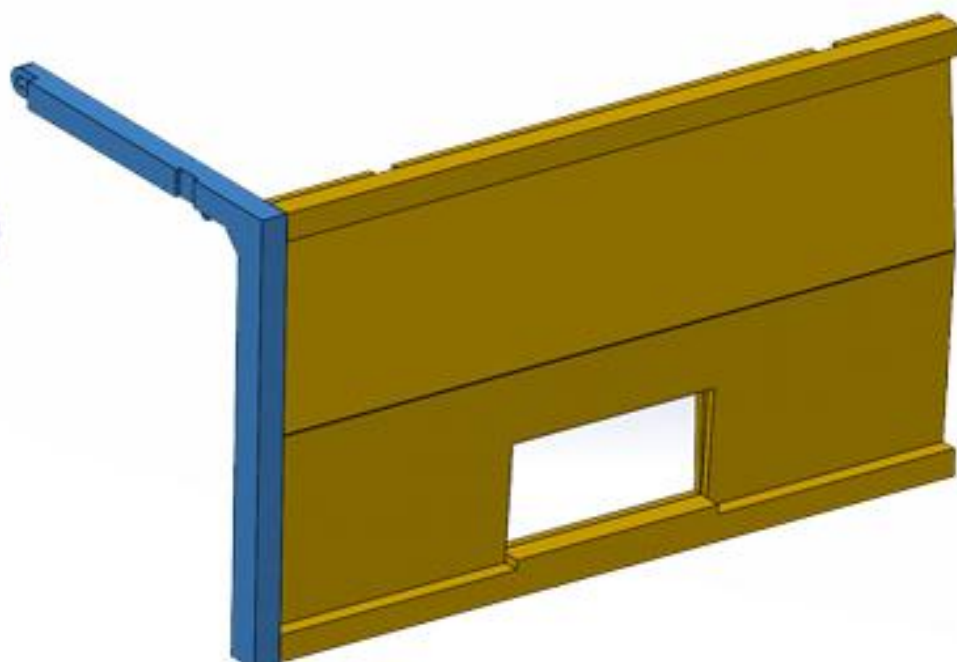



992K 19000

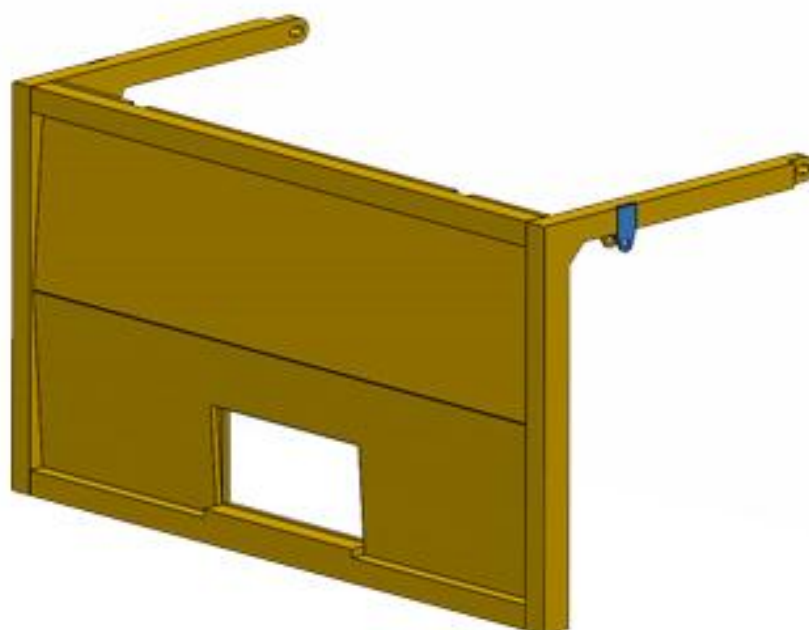
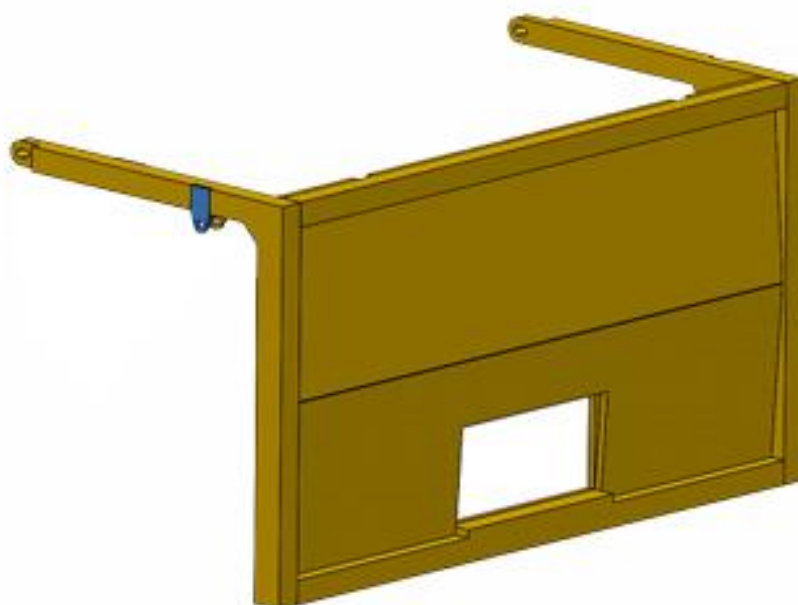
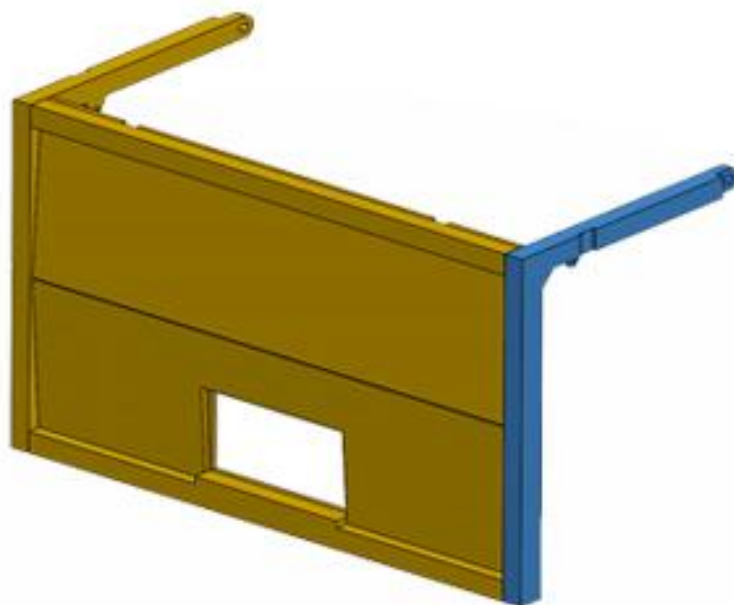



9927 19000

37:

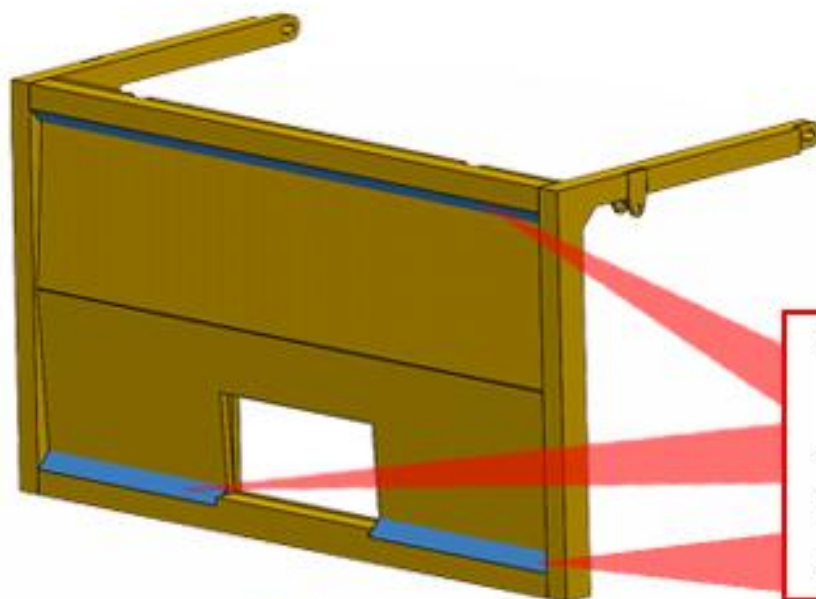

38:

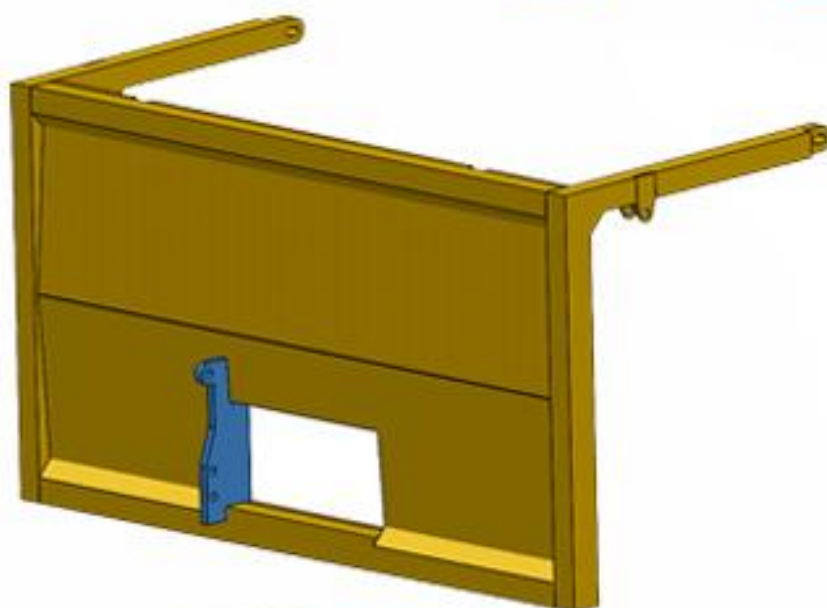

39:

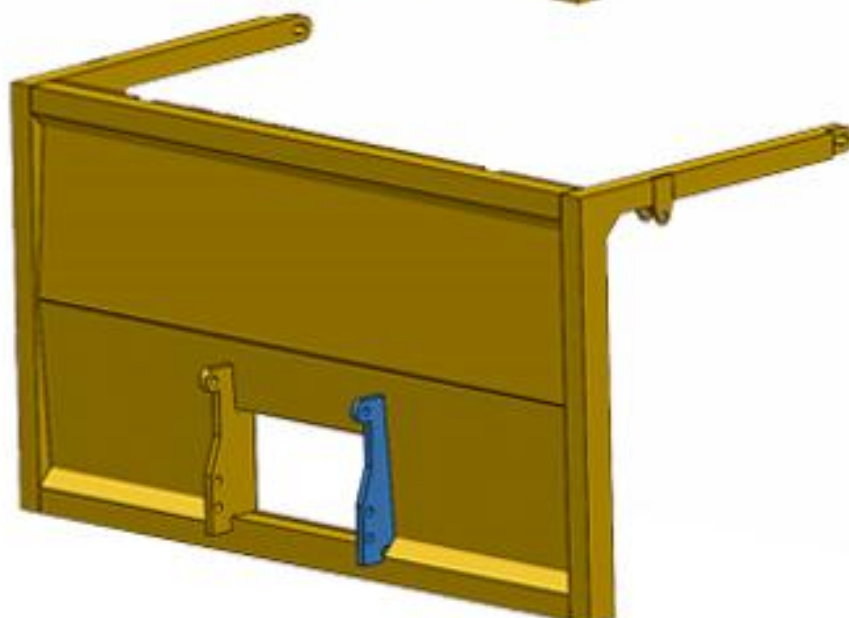



9927 19000

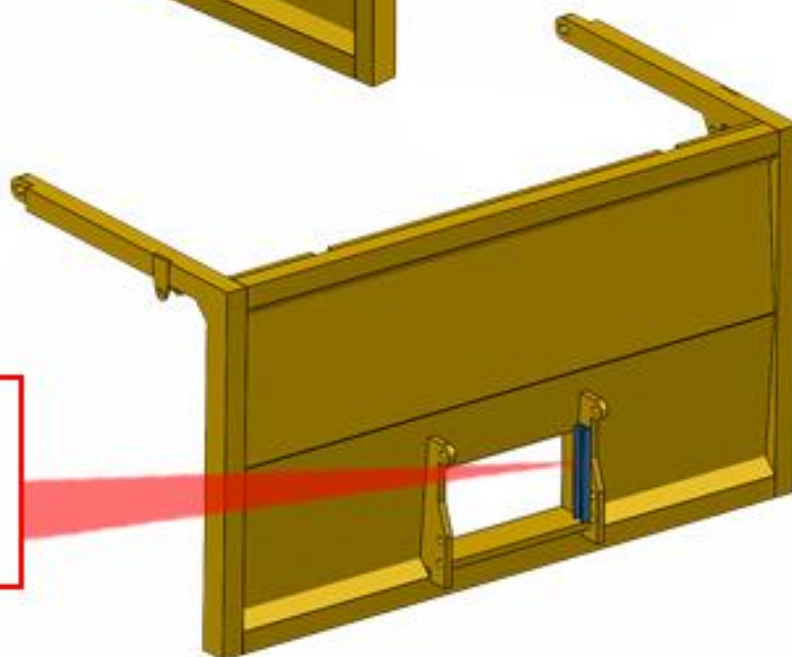
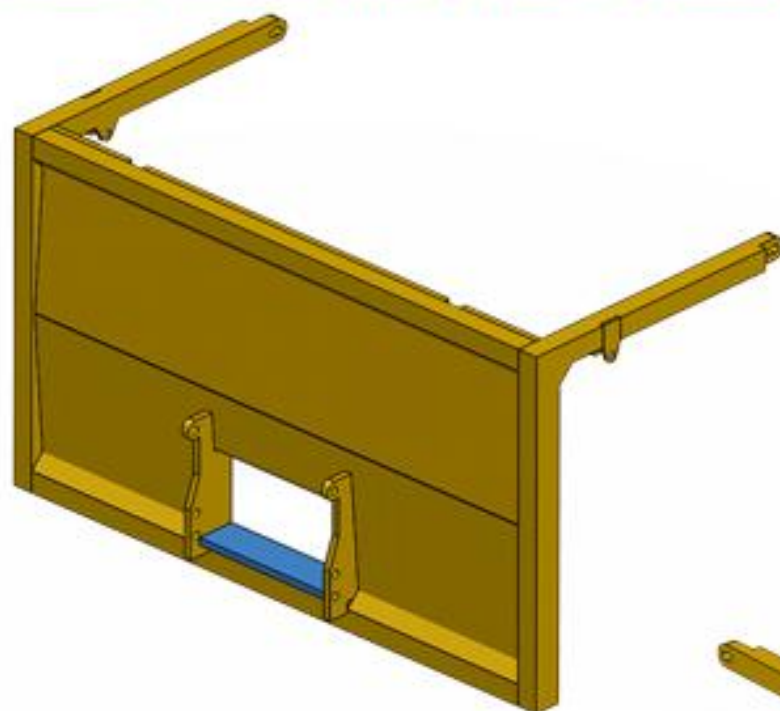

U-profiel 1x2 mm
Lengte 13 mm
Lengte 13 mm

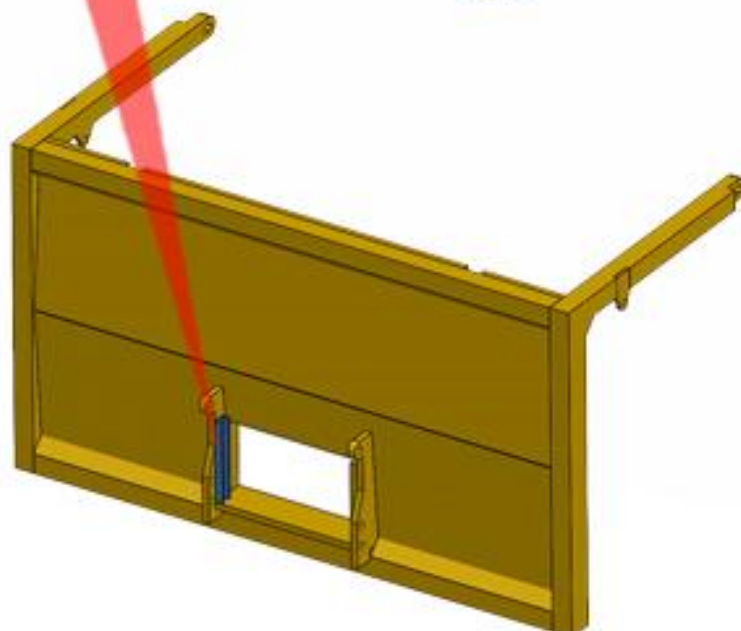



992K 19000

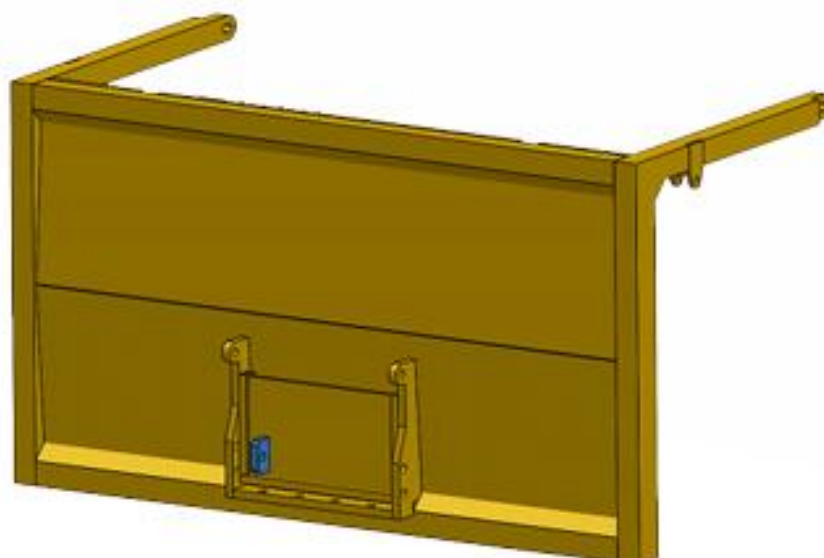
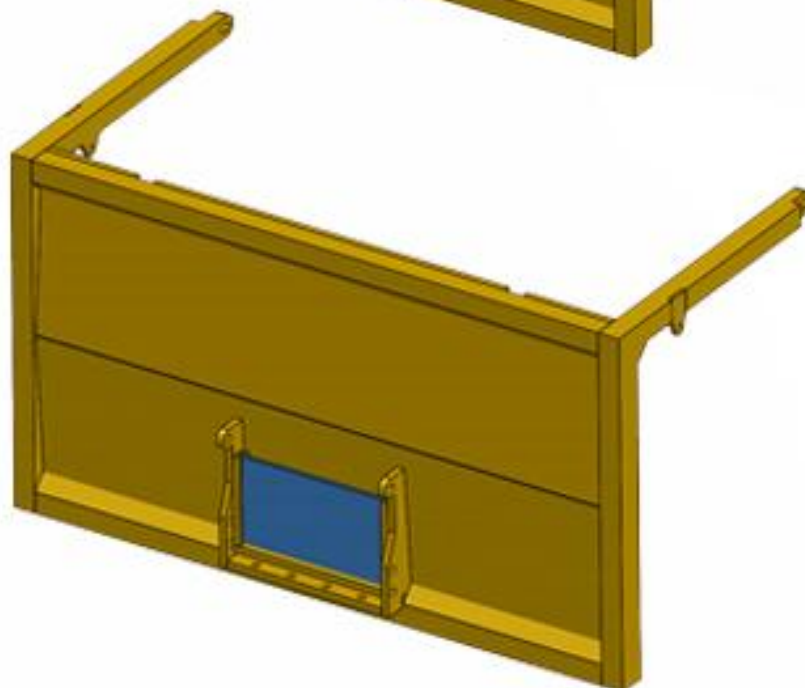
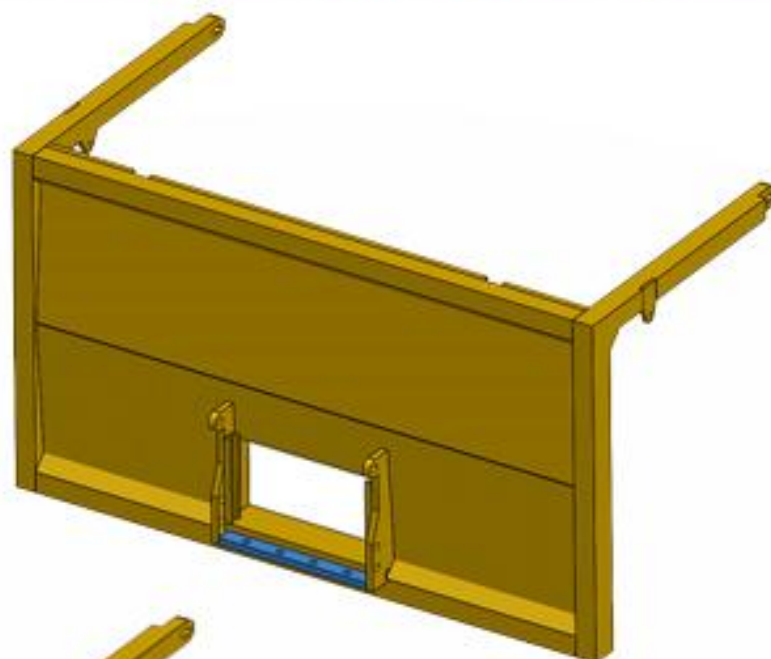



902K 19000

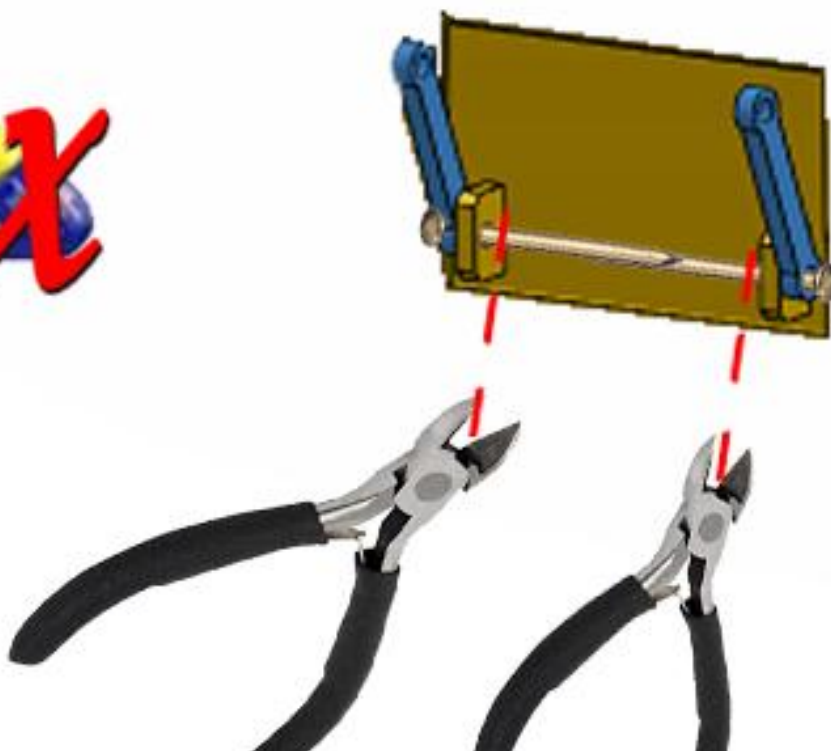
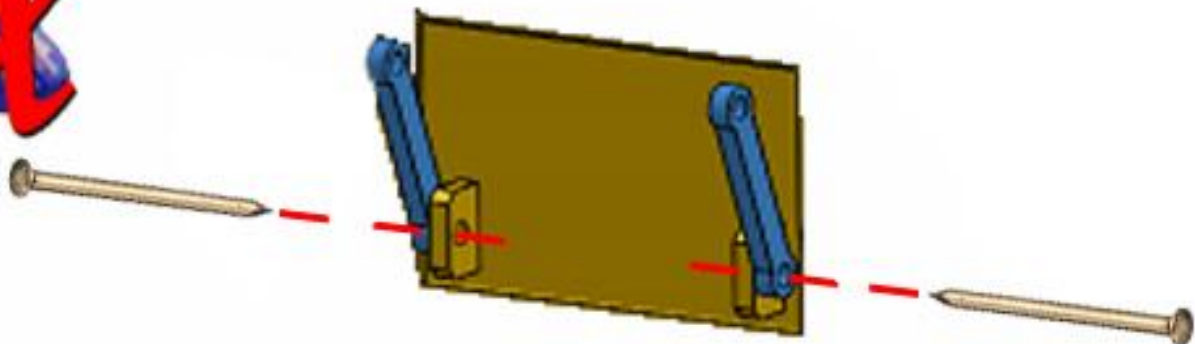
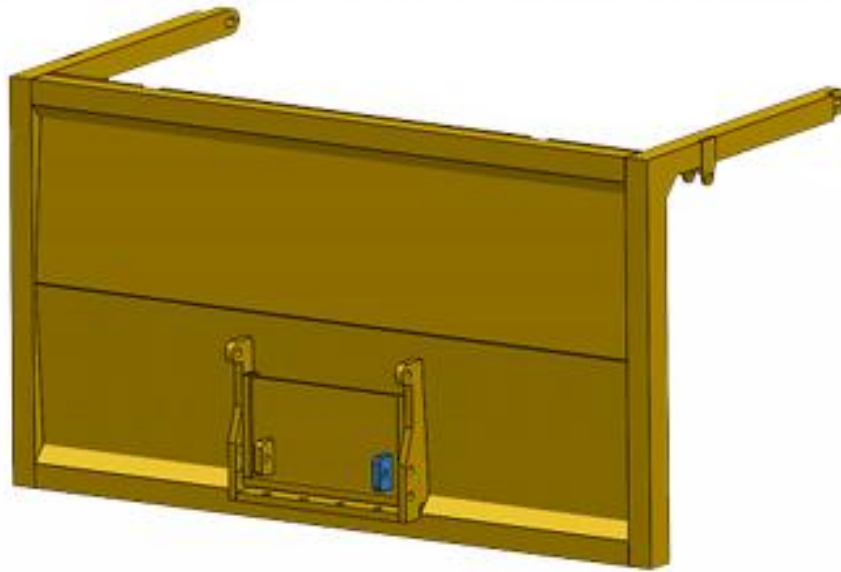

992K 19000

49:

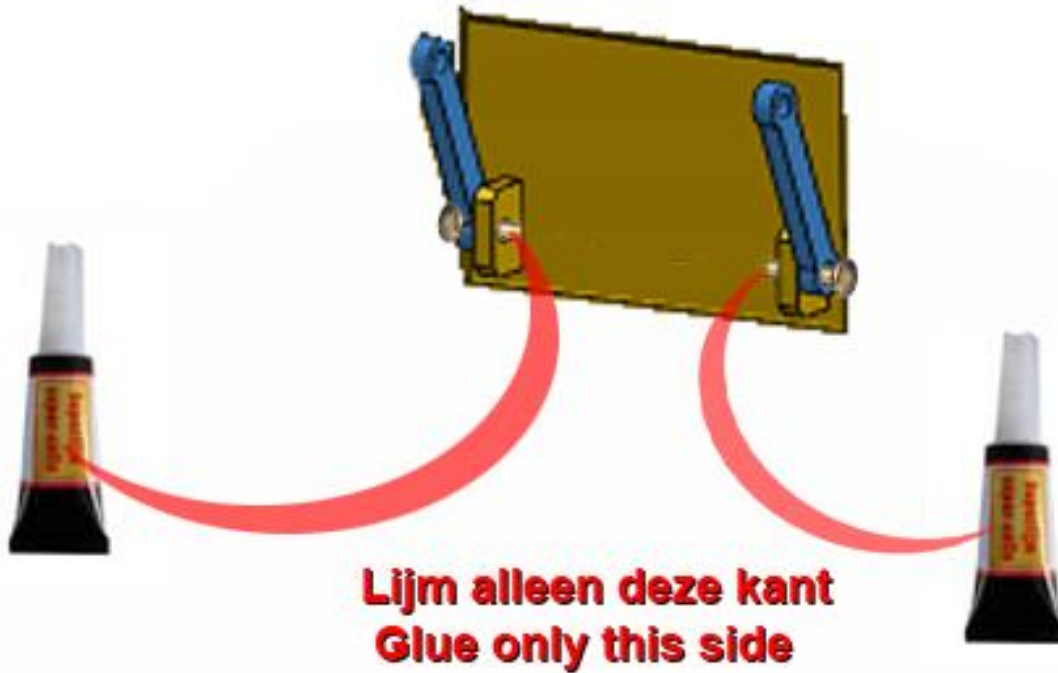

50:

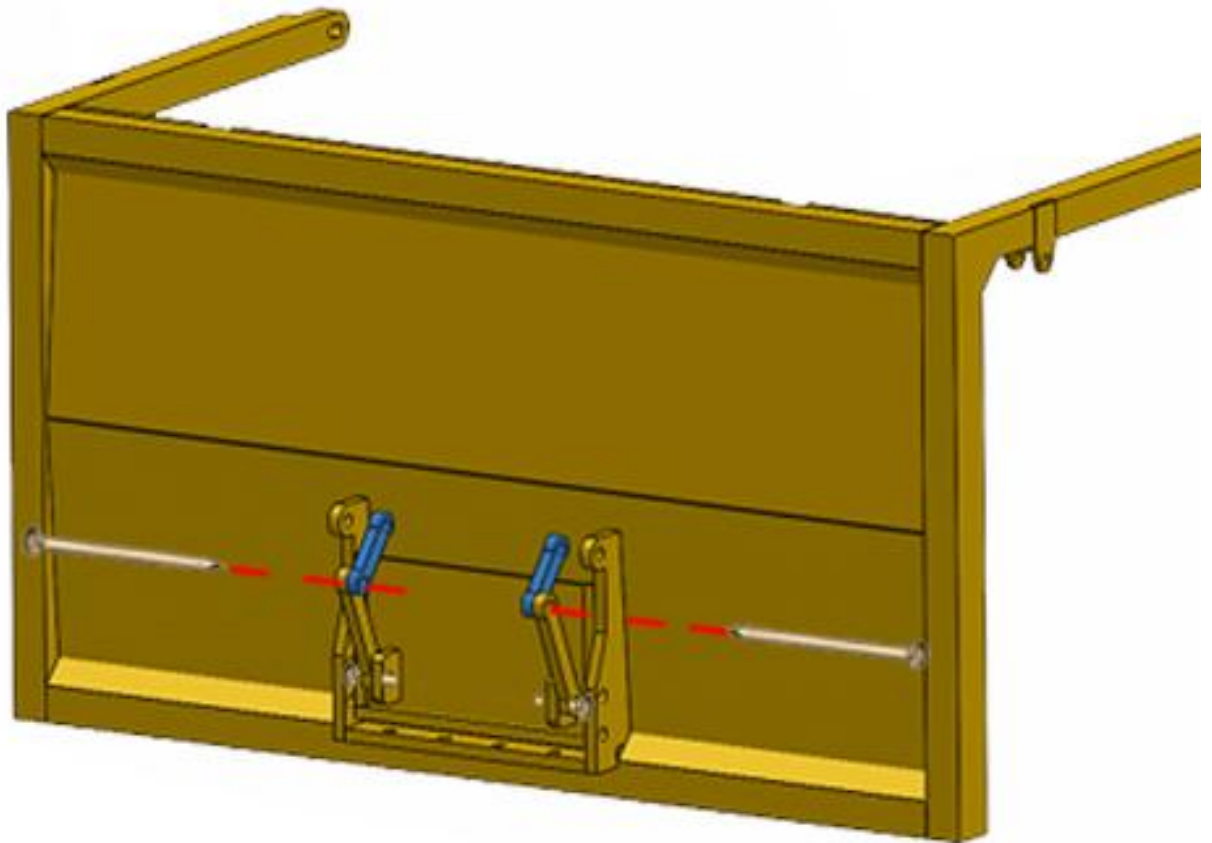

992K 19000

51:

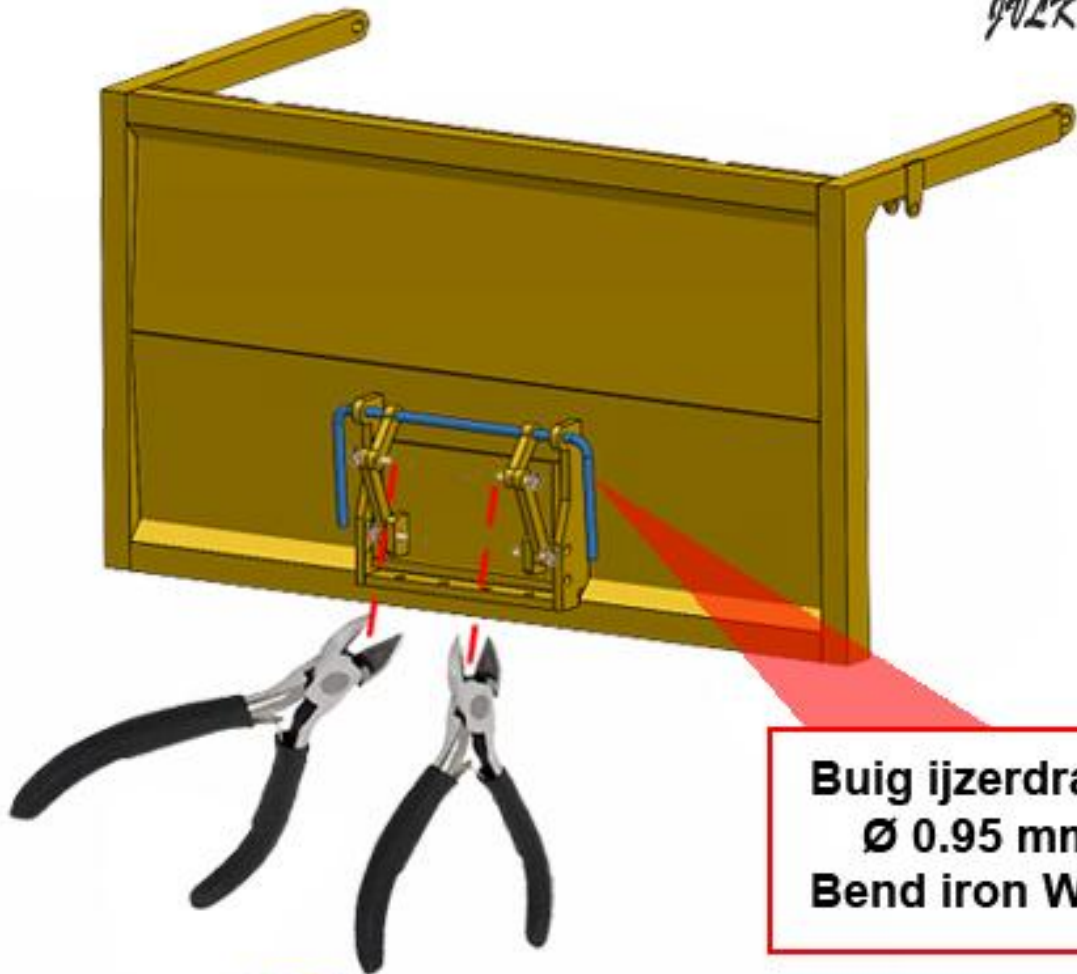

52:

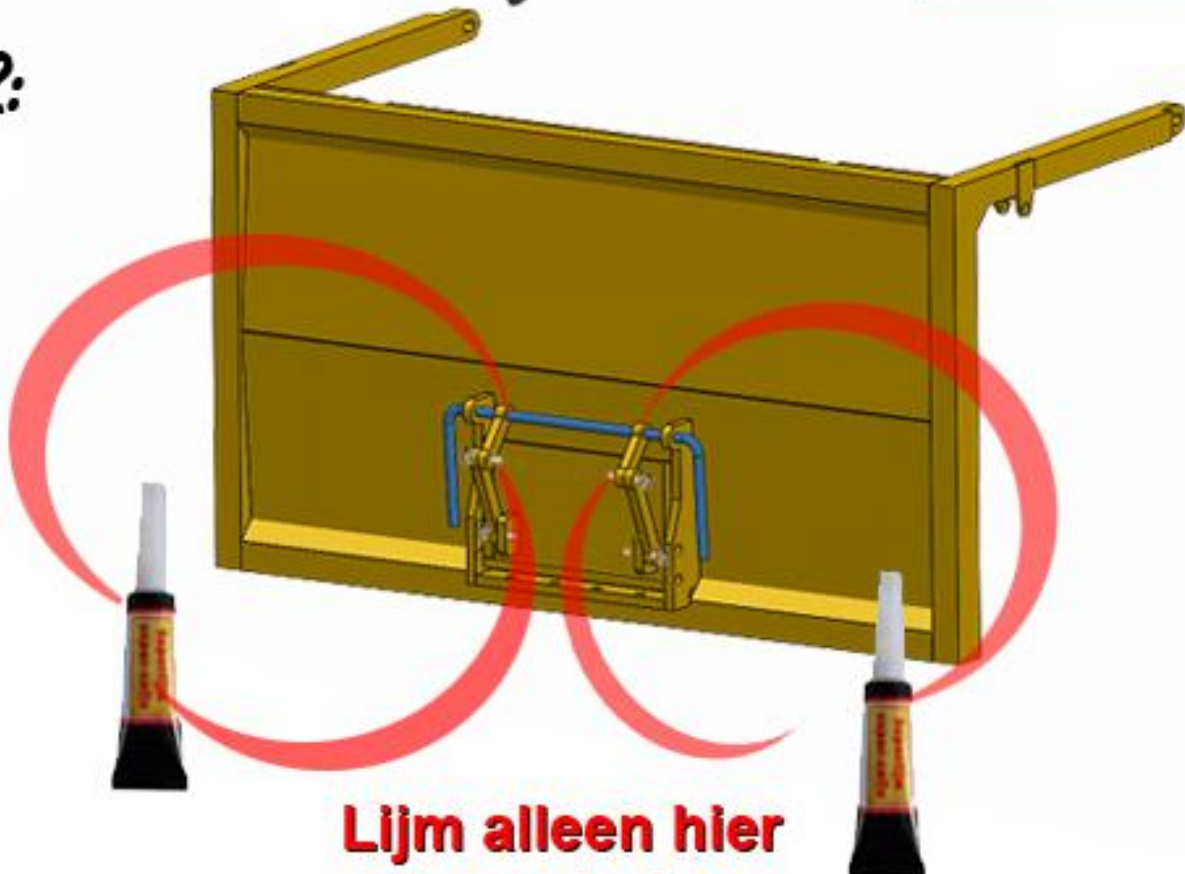

Lijm alleen hier
Glue only here



902K 19000

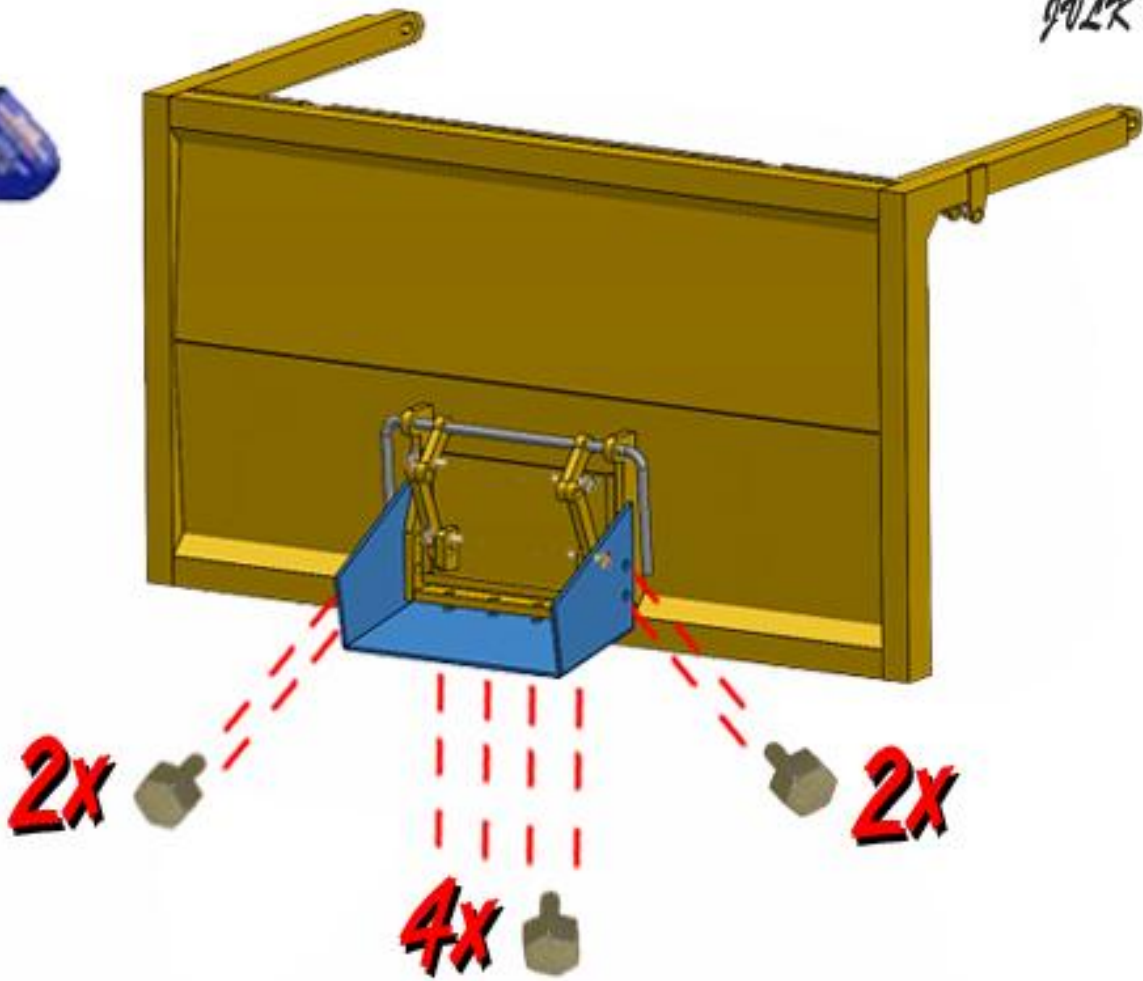

54:

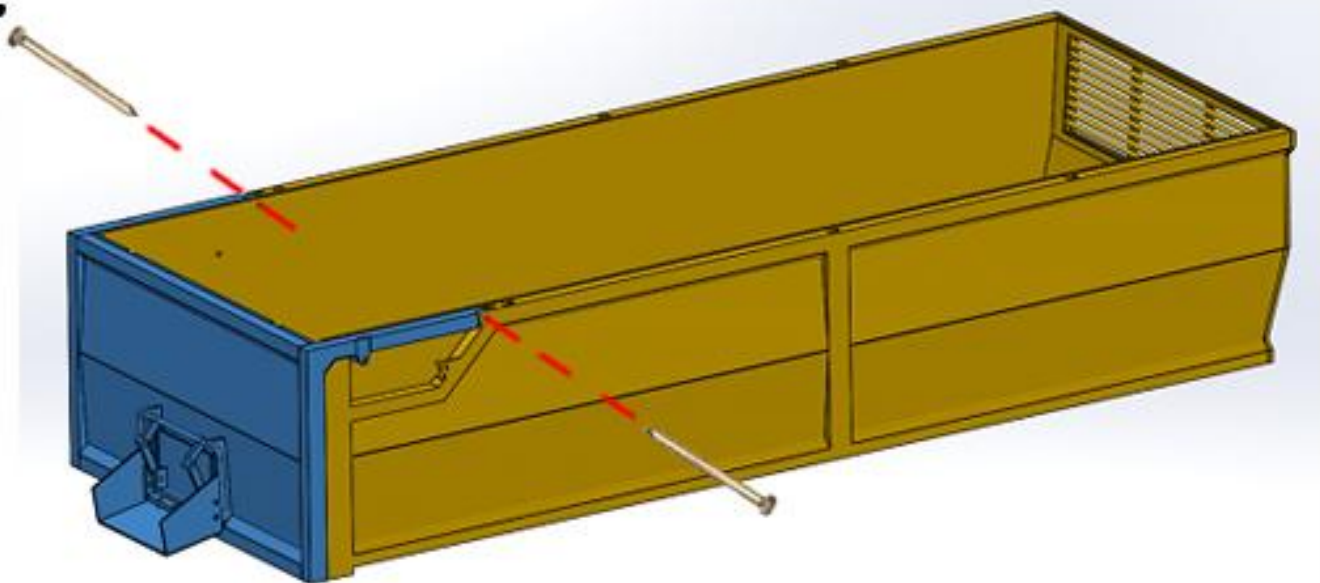

9927 19000

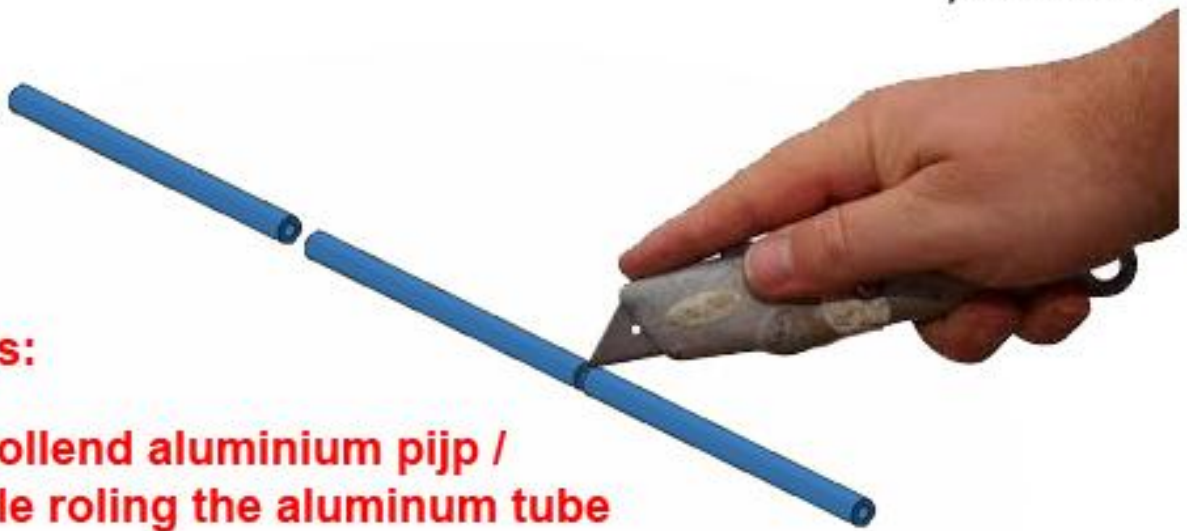

Cilinders:

**Snij al rollend aluminium pijp /
Cut while rolling the aluminum tube**

55: Aluminium pijp / pipe **A**

Ø 2 mm buitenmaat / outside

x

1 Ø 1 mm binnenmaat / inside

x

Lengte / lengths 19 mm

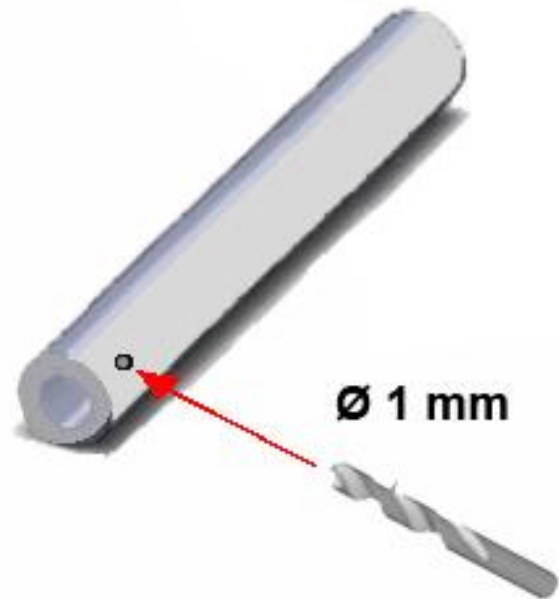

56: Aluminium pijp / pipe **B**

Ø 1 mm buitenmaat / outside

x

Lengte / lengths +- 25 mm



9927 19000

57:

Aluminium pijp / pipe **B**

Ø 1 mm buitenmaat / outside
x
Lengte / lengths +/- 25 mm

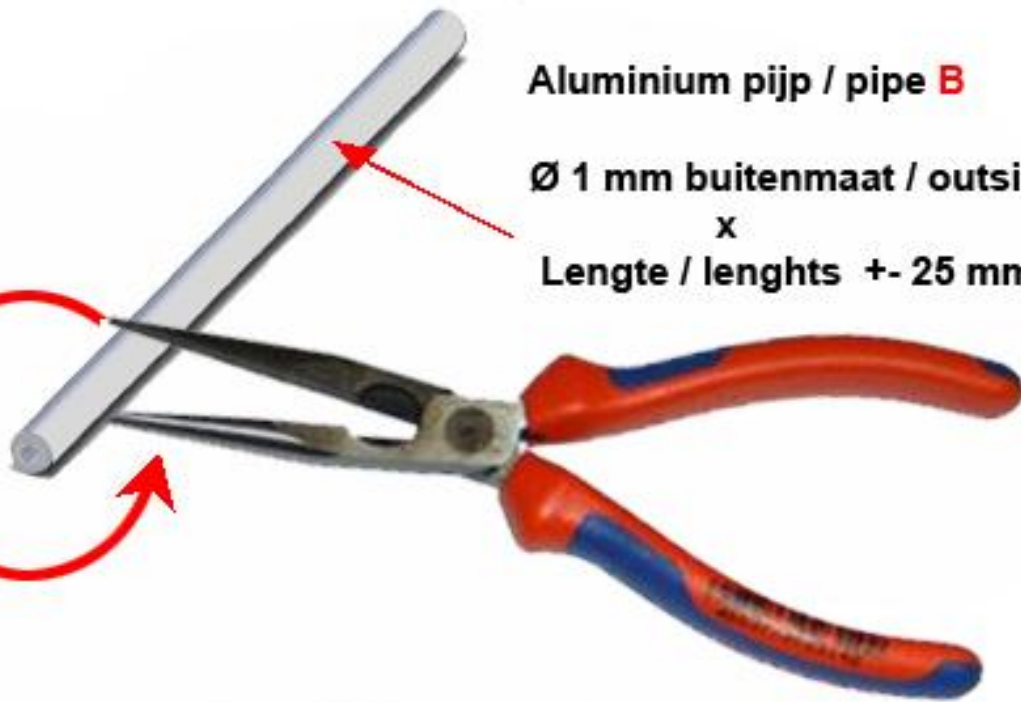

Aluminium pijp / pipe **B**

Lengte / lengths 17 mm

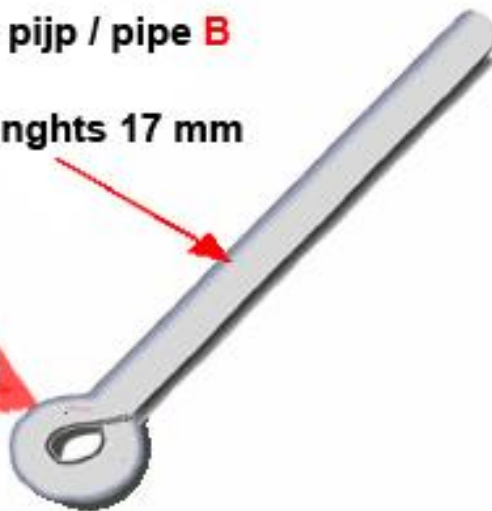

Aluminium pijp / pipe **A**

Aluminium pijp / pipe **B**

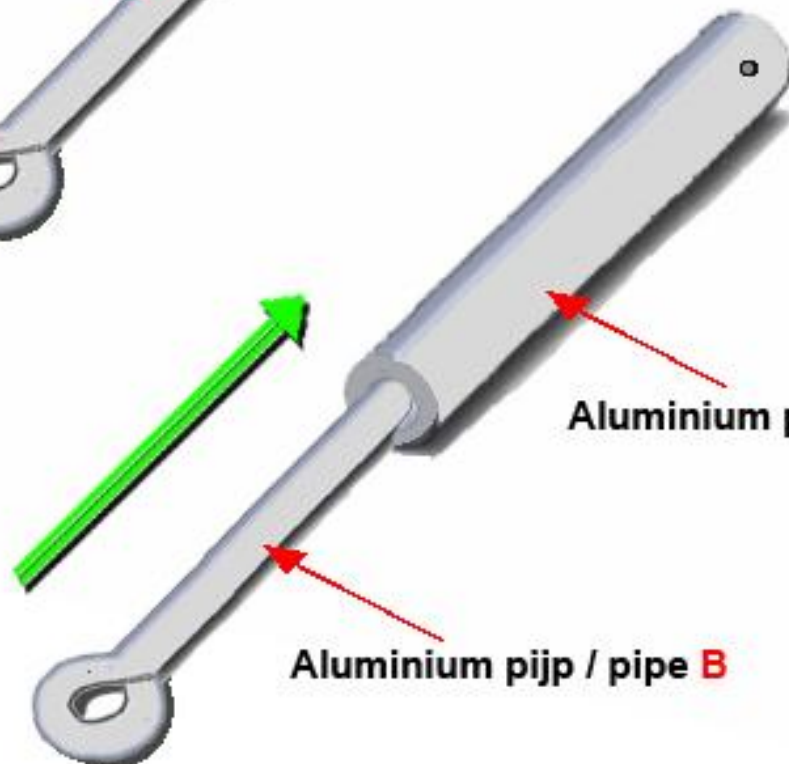

58:

2x Aluminium pijp / pipe **A**
2x Aluminium pijp / pipe **B**

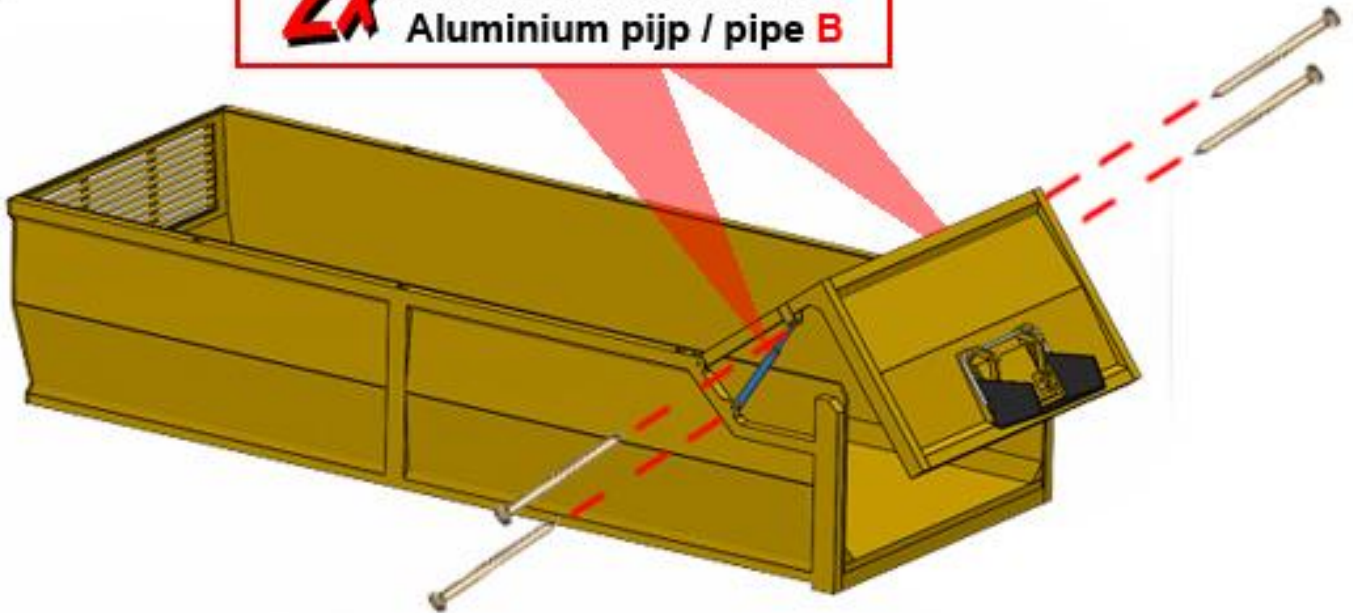

54:

U-profiel 2.5 x 5 mm
Lengte 12 mm
Length 12 mm

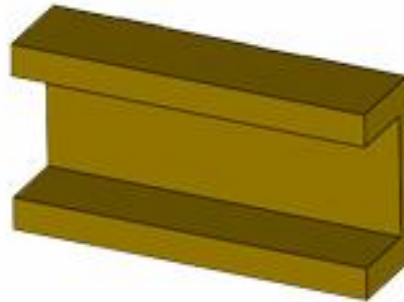

55:



IJzerdraad
Ø 0.95 mm
Iron Wire

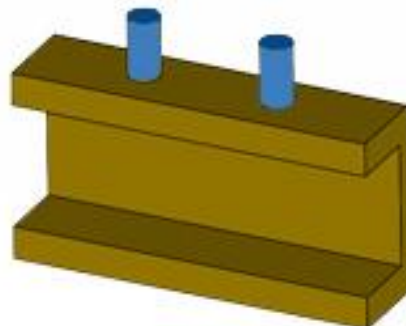



Farmmodels.nl

Landbouwmachines - Ouderdelen - Boorlijes - Stokers - Bioruimers



58:

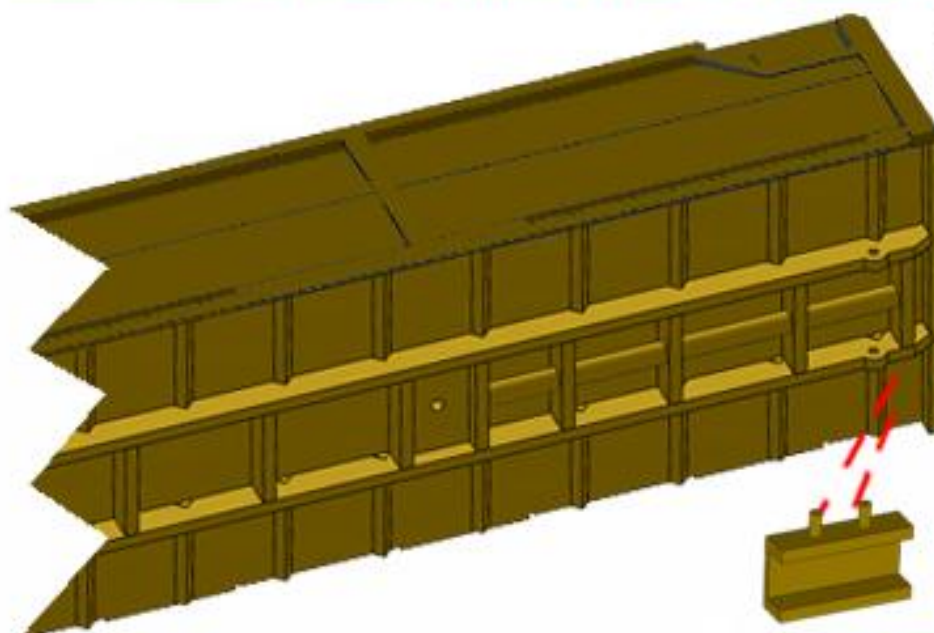

902K 19000

59:



**Bak Klaar,
Ready**