

# Farmmodels.nl

Landbouwminiaturen ~ Onderdelen ~ Bouwkitjes ~ Stickers ~ Dioramabouw

*Jan Veenhuis zandkip bak t.b.v. Haakarm Carrier*

*bouw handleiding*

## *Premium line series*



Beste modelbouwer,

bedankt voor de aanschaf van een Farmmodels bouwpakket.

U heeft hier de gedetailleerde beschrijving van uw bouwkit in schaal 1:32  
In fases wordt stap voor stap uitgelegd hoe u alle onderdelen samenstelt.

**Lees eerst alle fases goed door, voordat u begint.**

Het meeste freeswerk zit in de plaat vast met "bridges", dat zijn kleine stukjes om de gefreesde onderdelen in de plaat vast te houden.

Snij door deze bridges heen om de onderdelen los te maken.

Schoon daarna waar nodig het freeswerk op, verwijder eventuele resten en vijl alle scherpe hoeken / randen wat af.

Dat bevordert later het spuitwerk...

In deze beschrijving is niet aangegeven wanneer u het beste onderdelen van kleur / verf kunt voorzien, daar dit afhankelijk is van de door u gekozen kleurstelling. Hou daar zelf rekening mee tijdens de bouw.

Belangrijk is de juiste soort lijm te gebruiken.

Wij adviseren 2 soorten lijm:

Modelbouwlijm voor polysyreen (plastic / kunststof is Revell Contacta en secundelijm / industrie lijm.

Gedurende de bouw wordt verteld met welke lijm gewerkt dient te worden.

Deze handleiding is zo goed mogelijk samengesteld.

Mocht u derhalve toch vragen hebben, of punten opmerken ter verbetering van de handleiding, kunt u ons mailen op [info@farmmodels.nl](mailto:info@farmmodels.nl).

Wij wensen u veel "modelbouw" plezier met het samenstellen van dit model.

Met vriendelijke groet,  
Team Farmmodels.nl

Benodigheden voor de bouw:

Voor de bouw van onze kitjes is het makkelijk om over het volgende gereedschap te beschikken:

\* Revell mes of Stanley mes



\* Vijl en schuurpapier



\* Pincet



\* Zijkniptang



\* Punt tang



\* diverse (staal) boortjes



• Lijm

○ Modelbouwlijm,



Advies: Revell Vloeibare plasticlijm.

*Deze lijm droogt niet direct en geeft de mogelijkheid om delen te positioneren.*

○ Secondelijm



Advies: Farmmodels super lijm.

*Deze lijm droogt direct zodat delen niet lang vastgehouden hoeven te worden.*

Gedurende de bouw wordt aangegeven welke lijm het meest geschikt is.



1: **Start:** Linker zijkant  
Left version

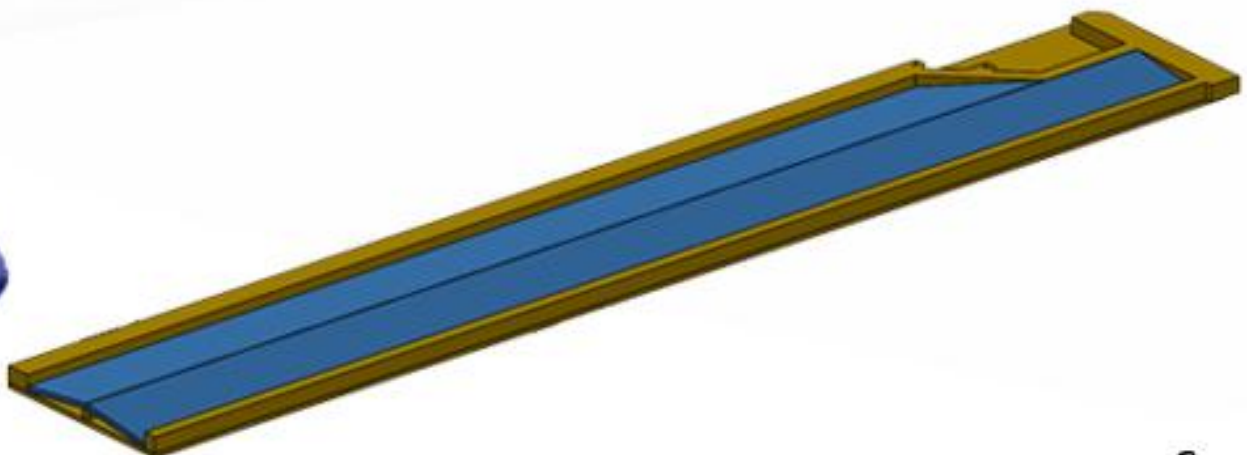
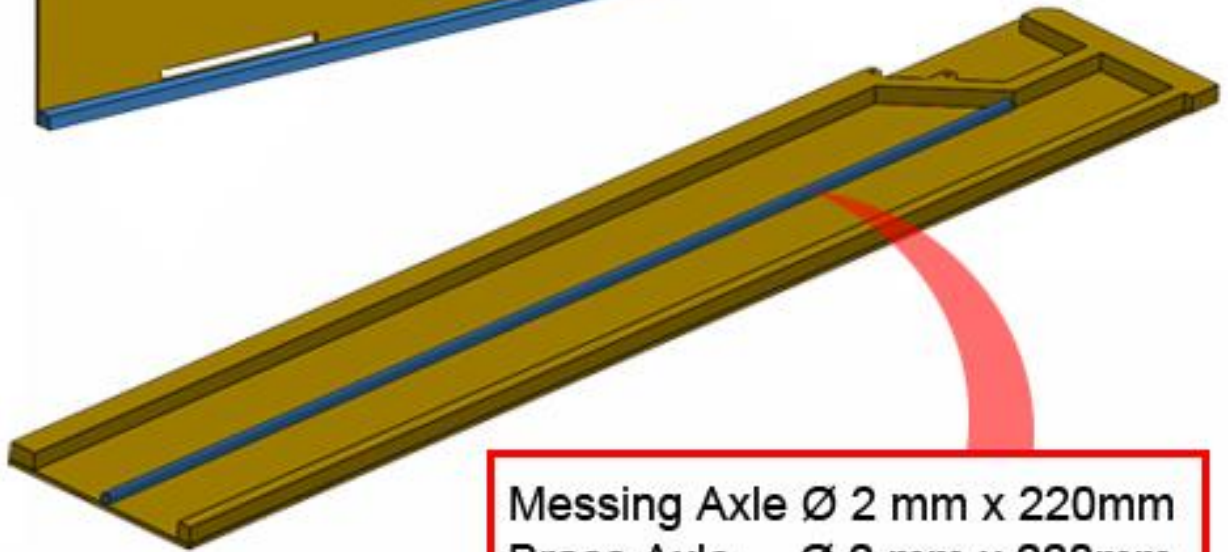
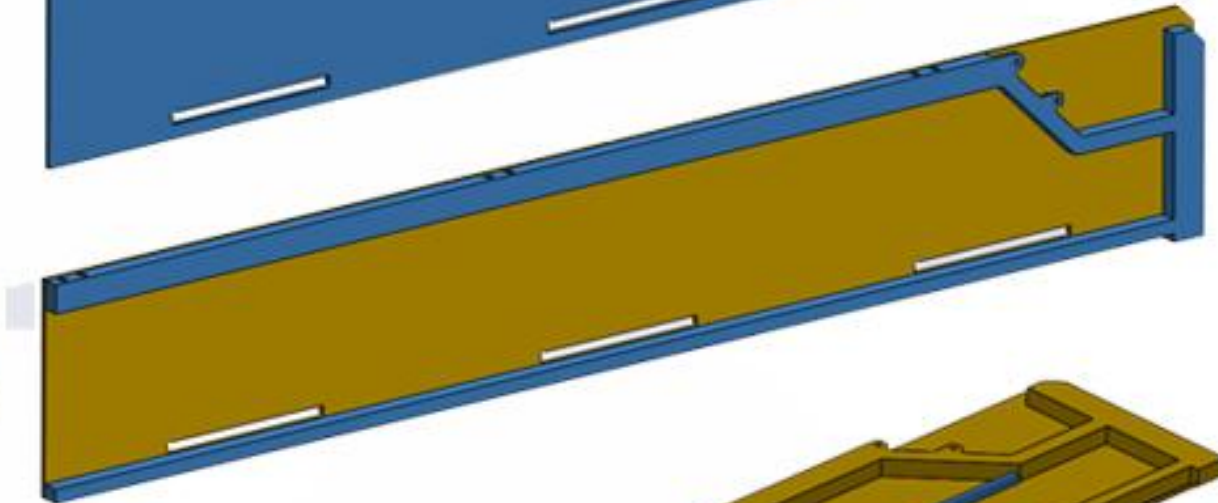



*Maak nu de rechter zijkant zoals stap 1 t/m 4*  
*Now make the right version like step 1 to 4*



6:



7:





*Gebruik de linker versie zijwand*  
*Use left version side wall*

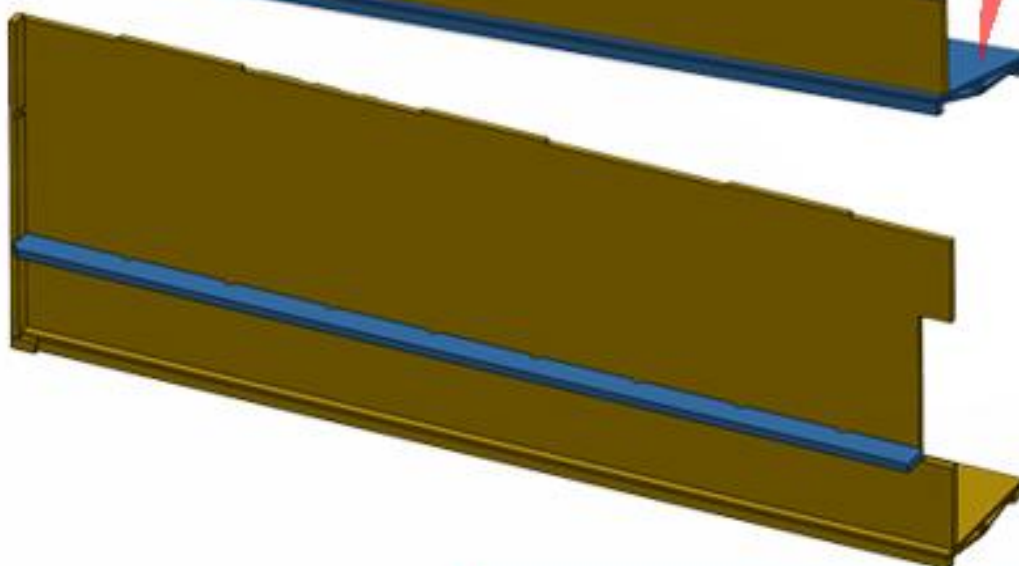

$2 \begin{array}{c} \triangle \\ 2 \end{array}$  Polystyreen 2x2 mm

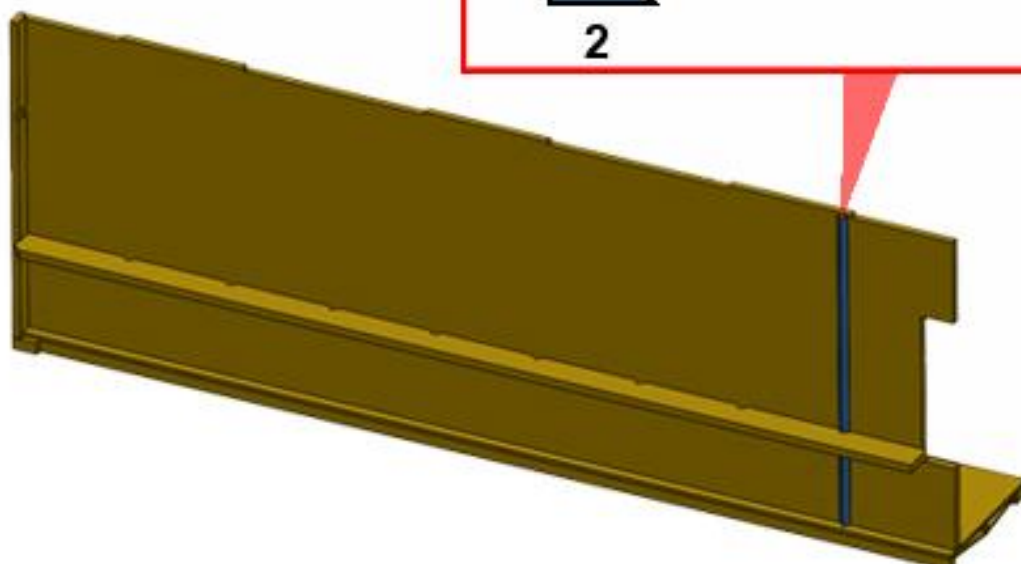

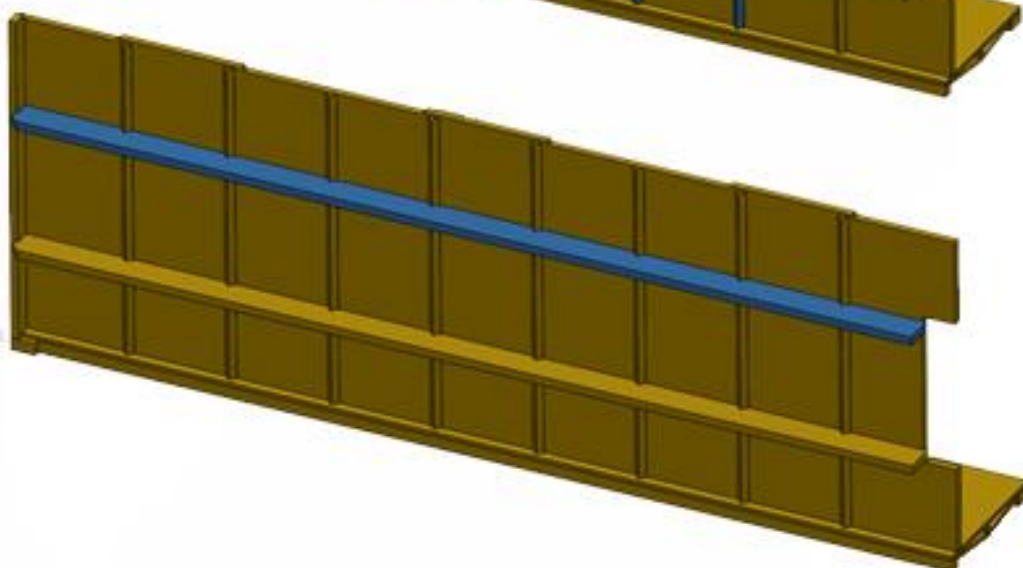
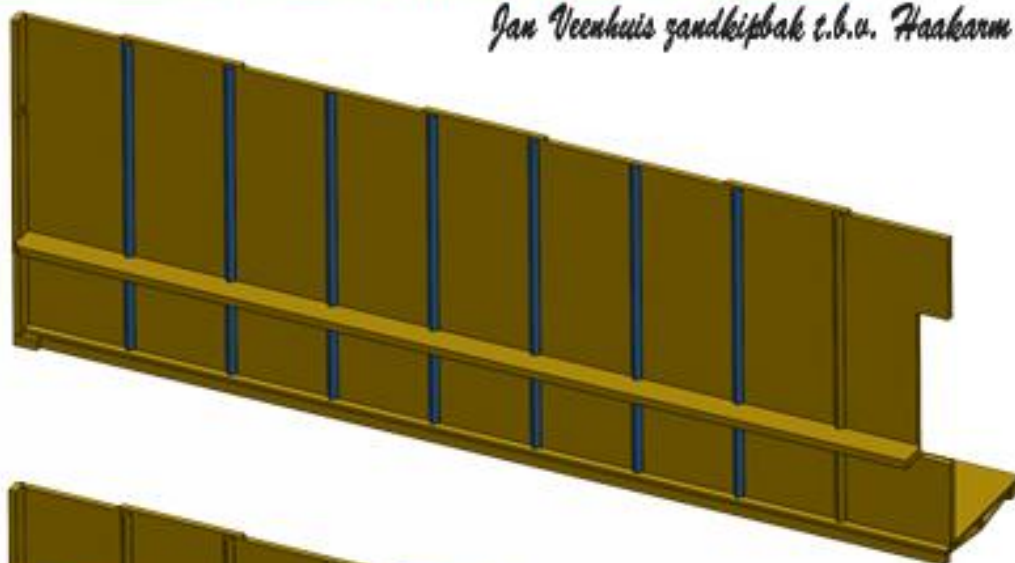

***Gebruik de rechter versie zijwand***  
***Use right version side wall***

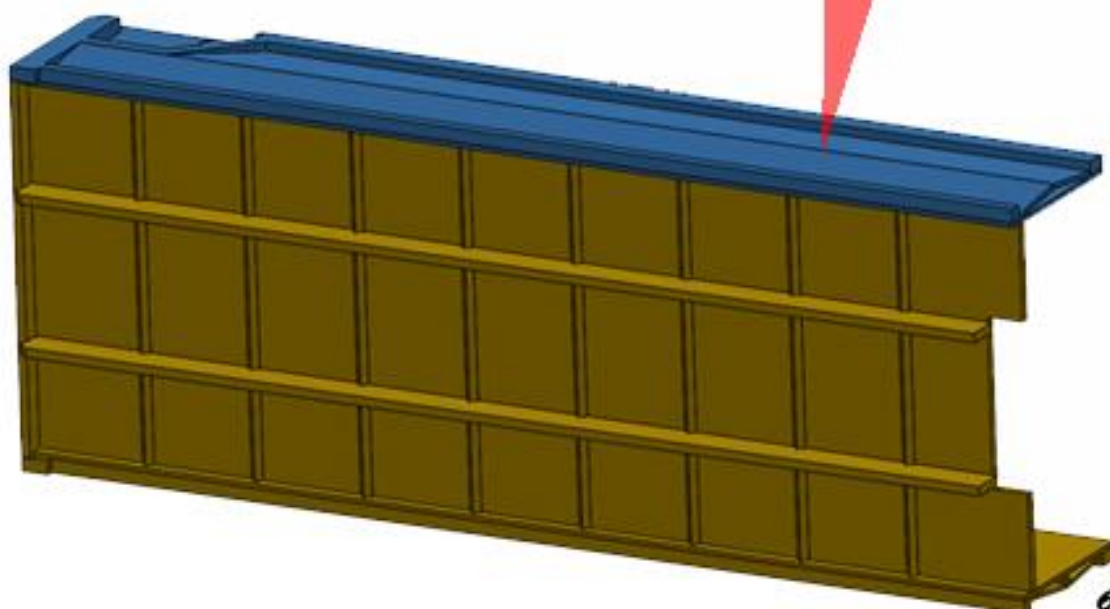

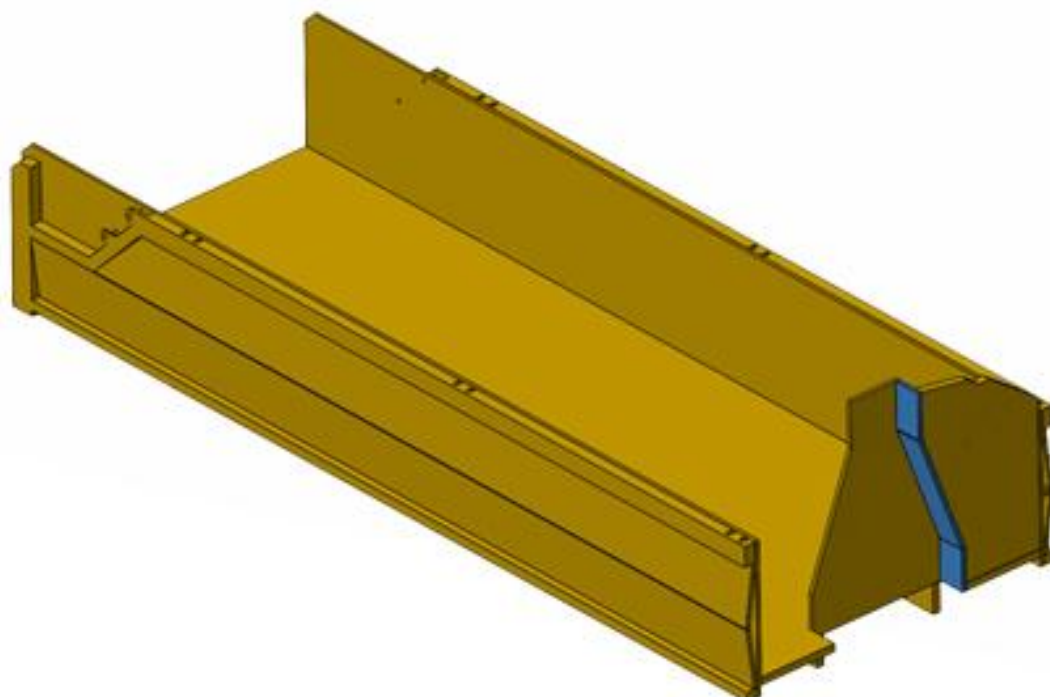
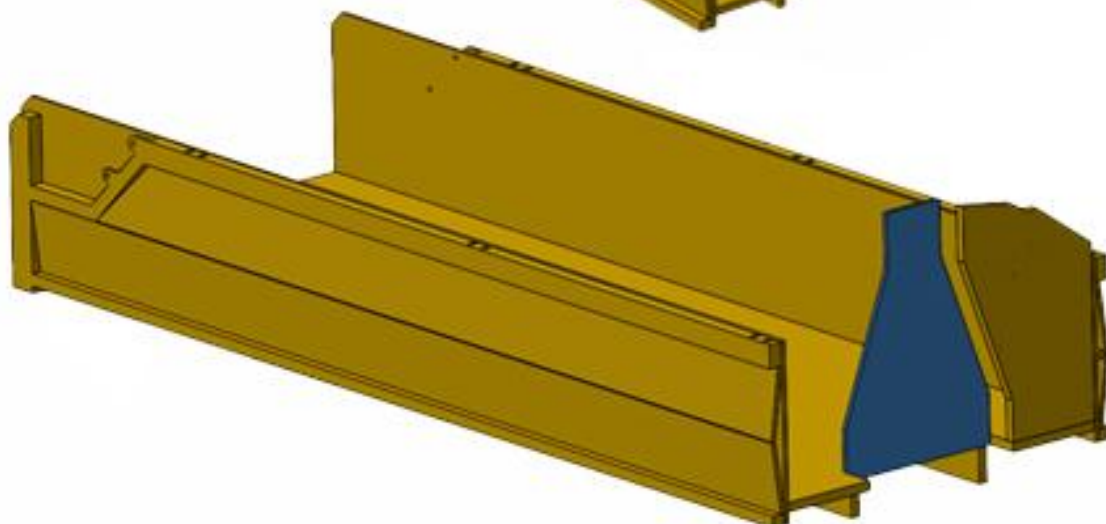
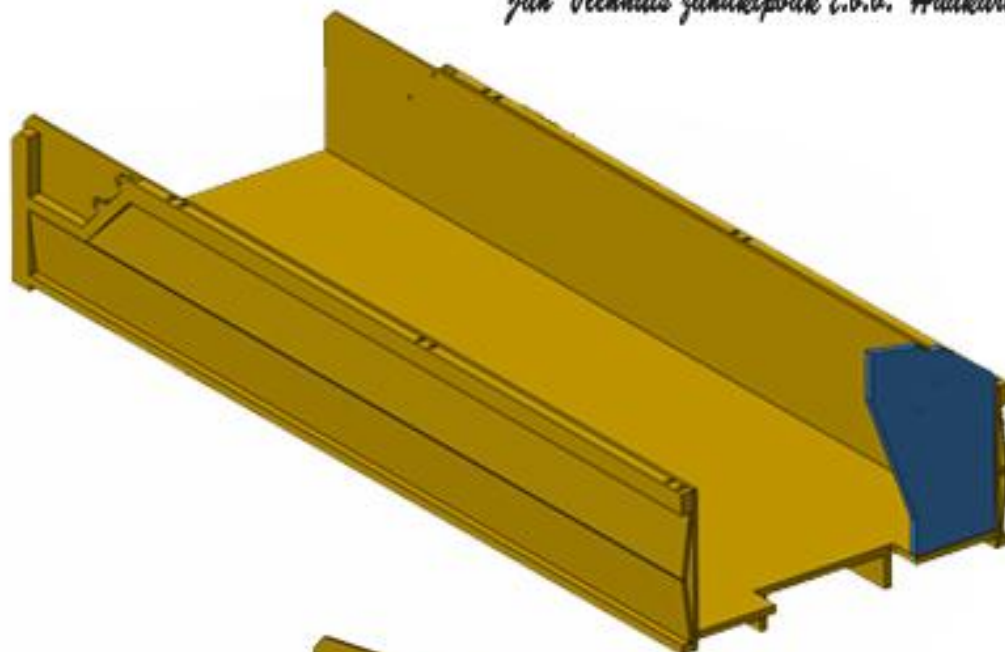

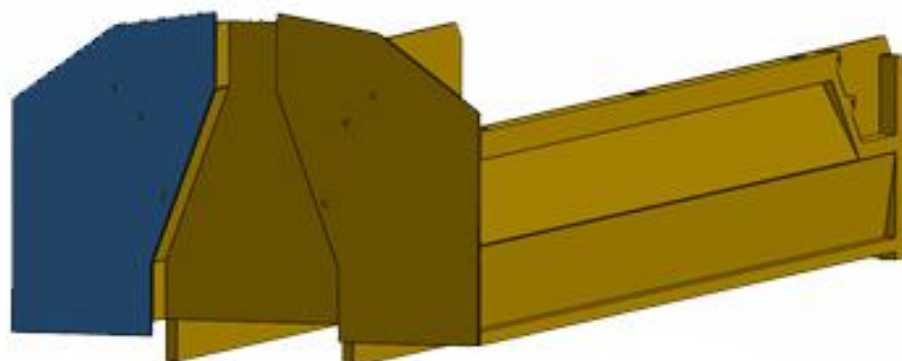
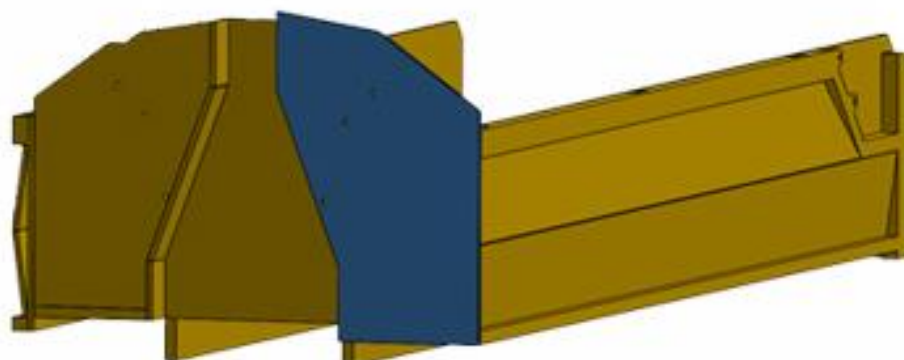
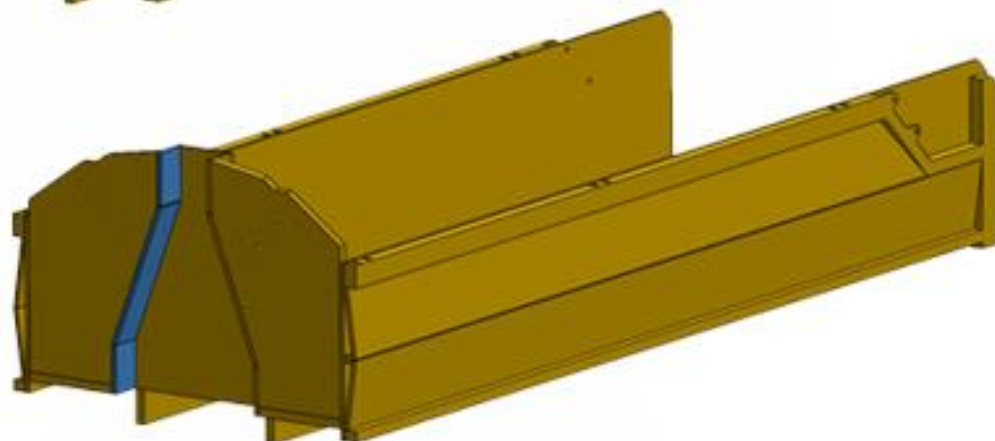
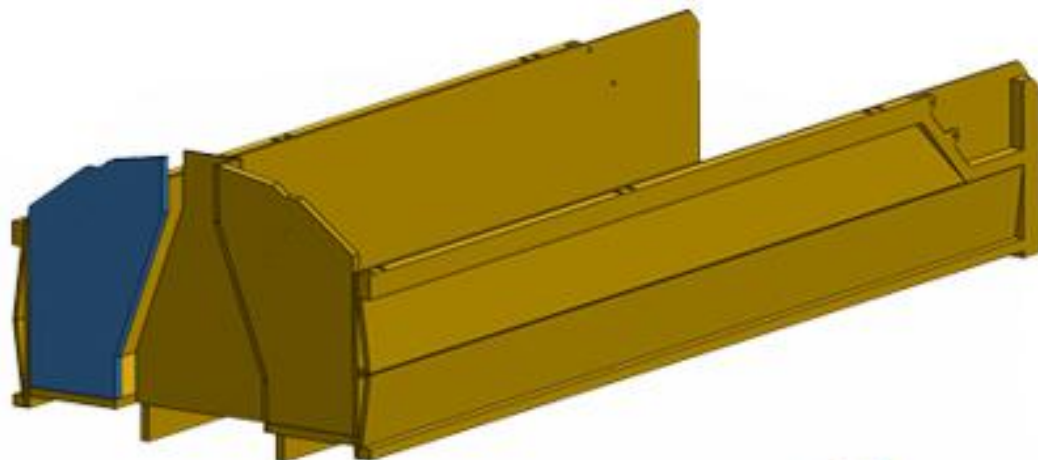



21:

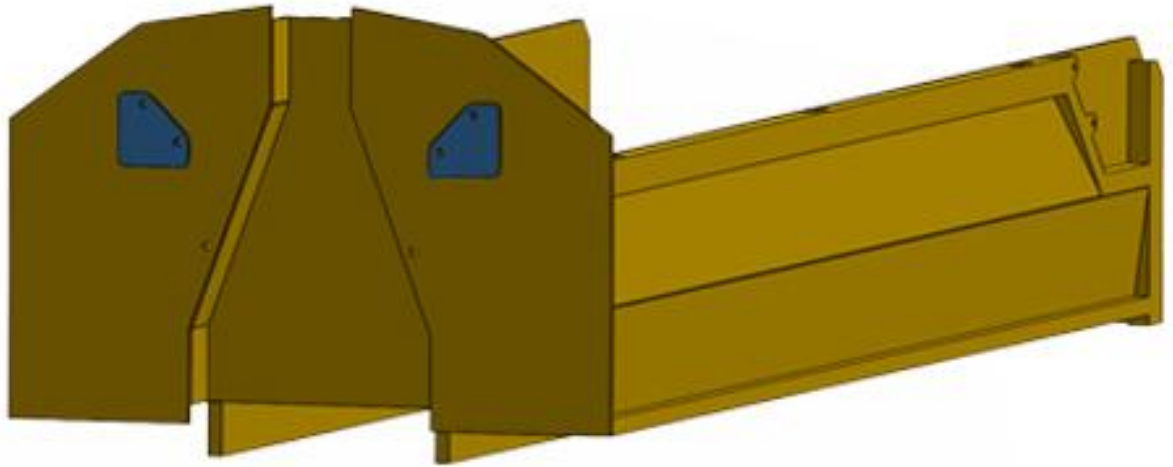

22:

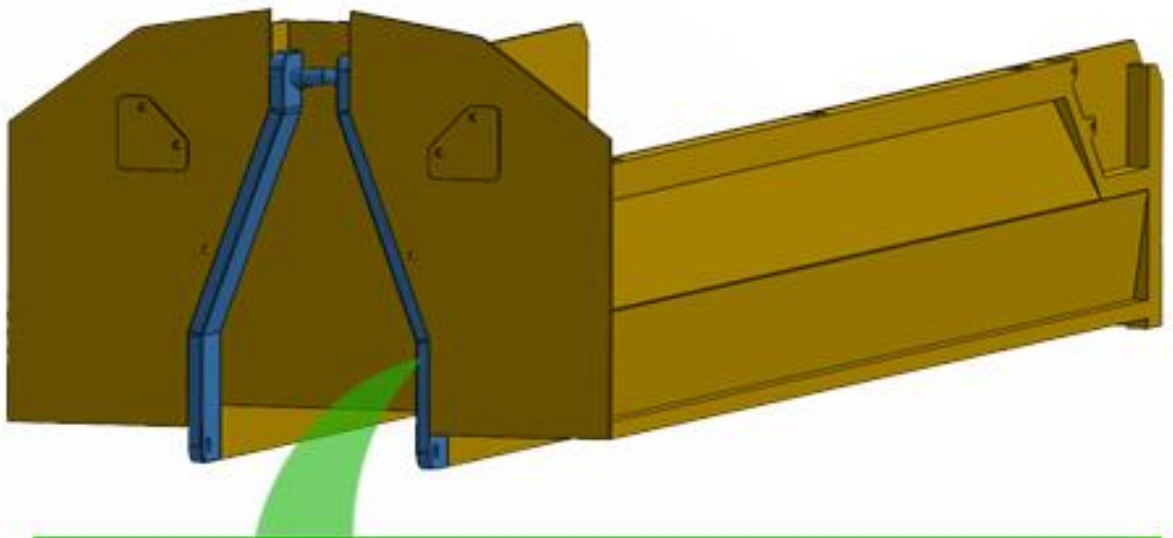

*Tip: Spuit dit 3 D geprinte deel meerdere malen in de Grondverf en Filler voor de definitieve laklaag !!!*

*Tip: Spraypaint this 3 D printed part first in several layers of Primer and Filler before the final color !!!*



23:

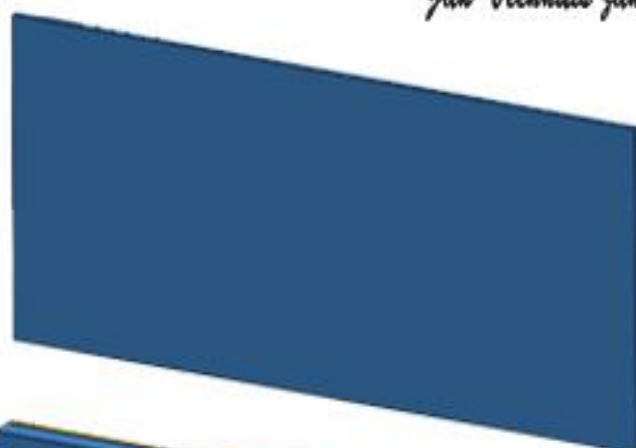

24:

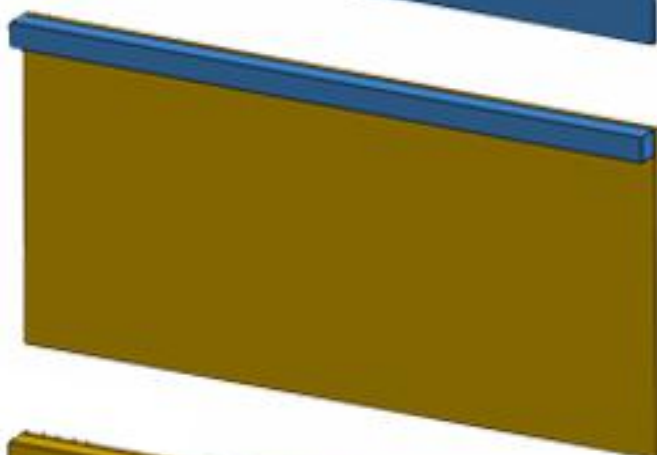

25:

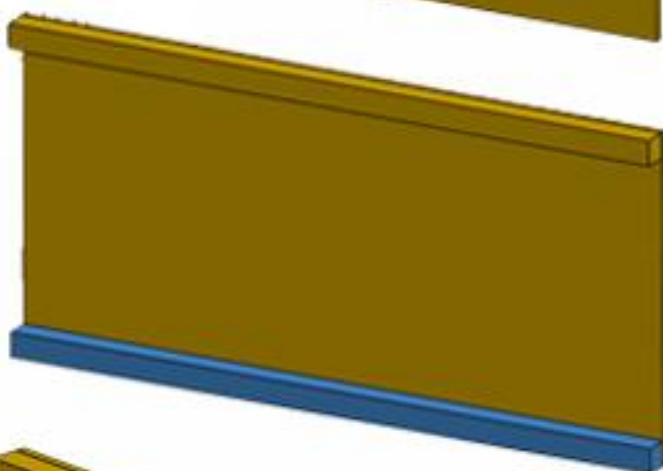

26:

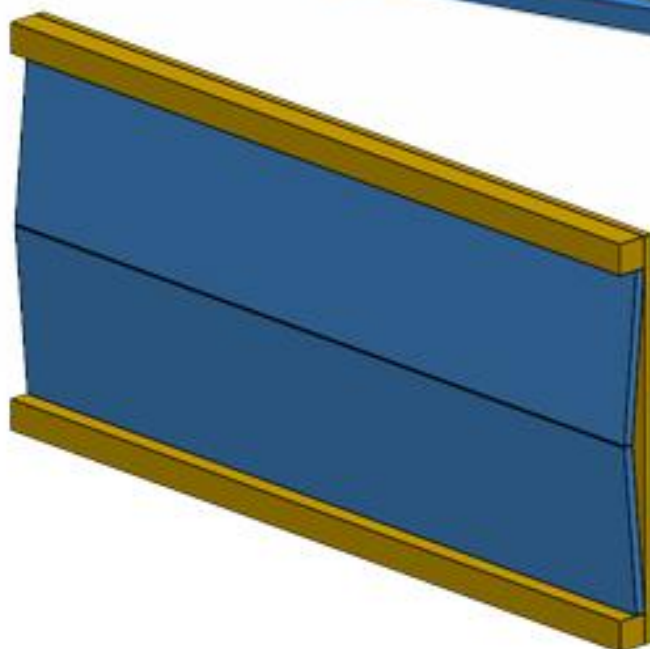



27:

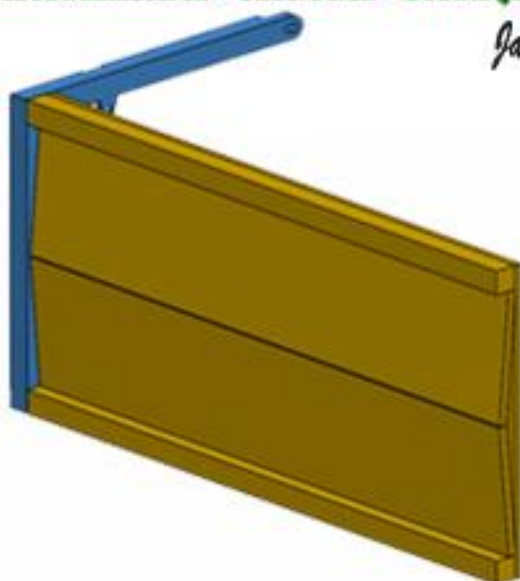

28:



29:

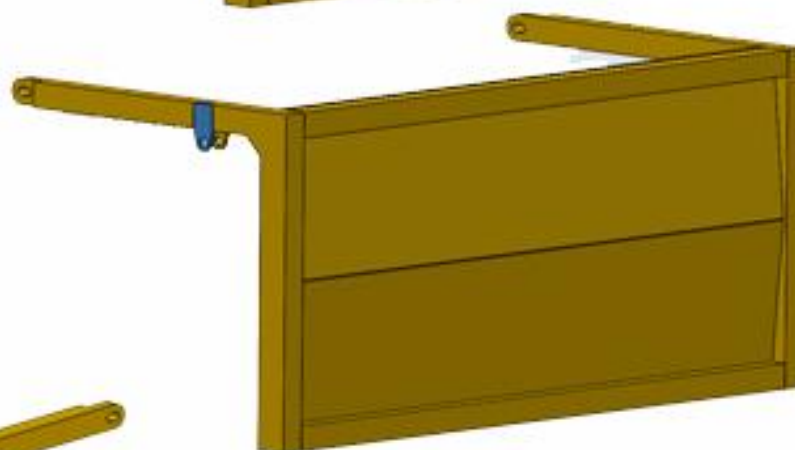

30:

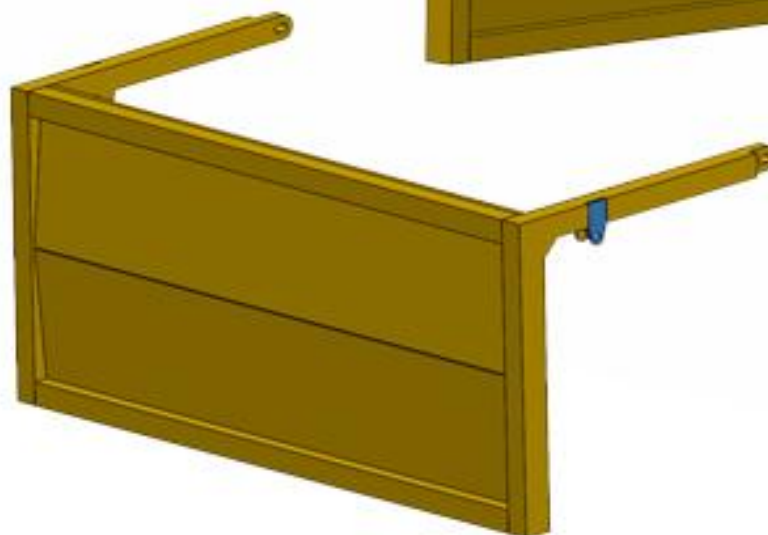



31:

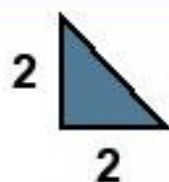
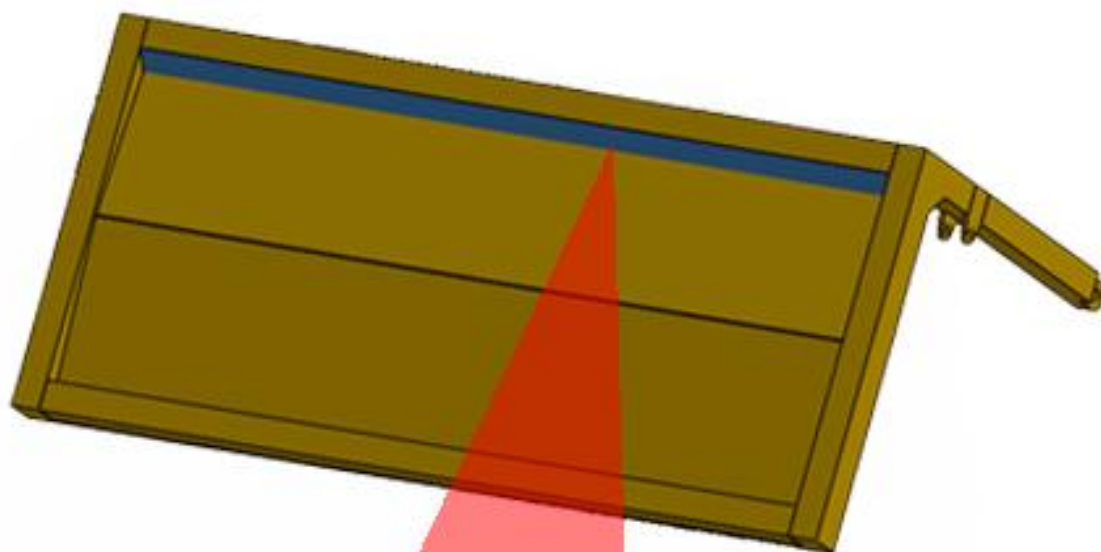

Polystyreen 2x2 mm

32:

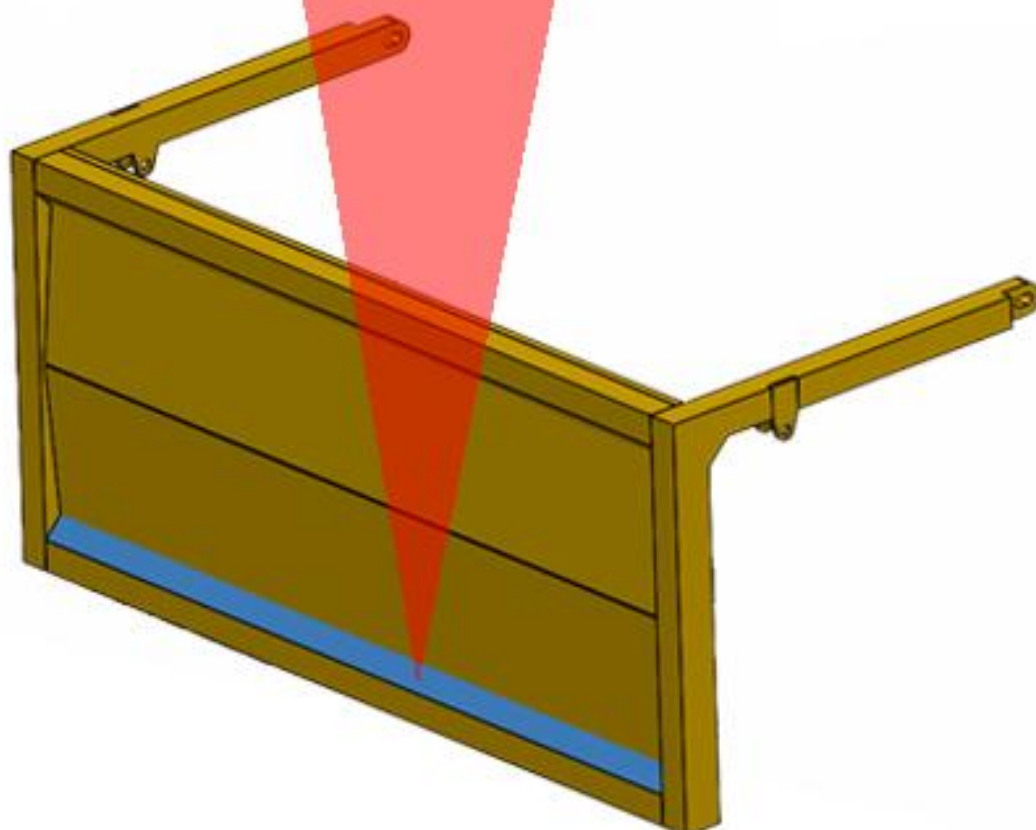

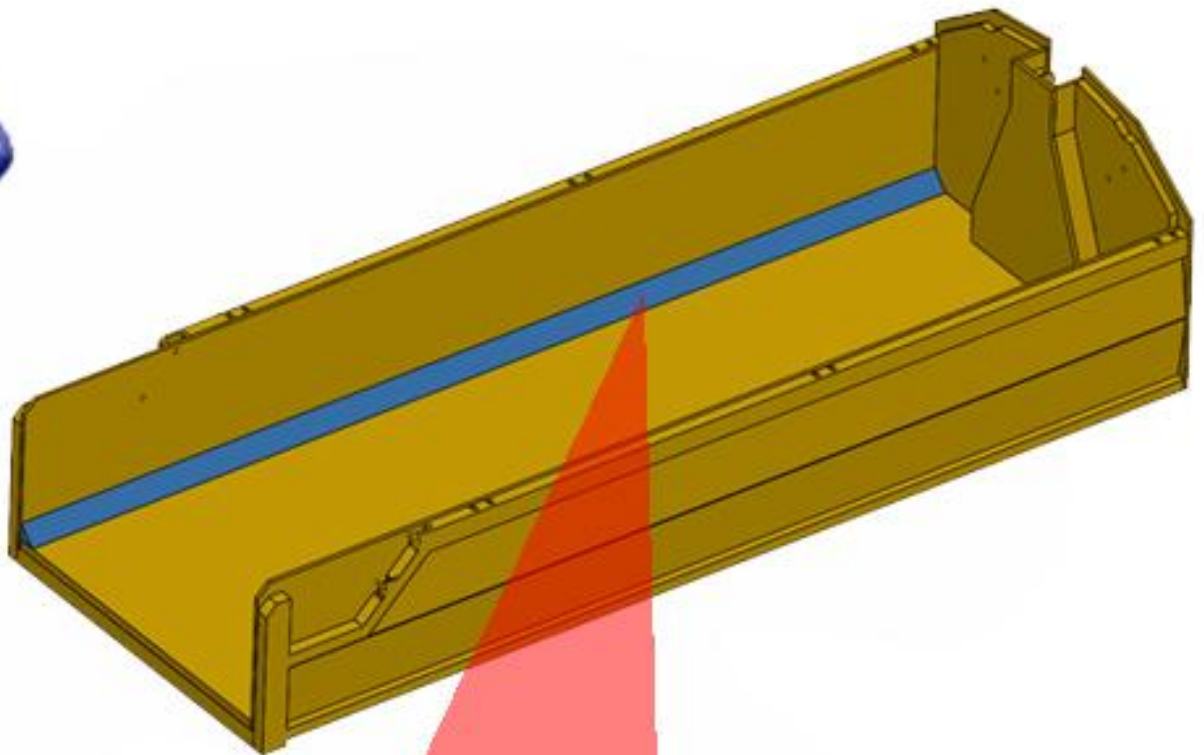

4  Polystyreen 4x4 mm  
4

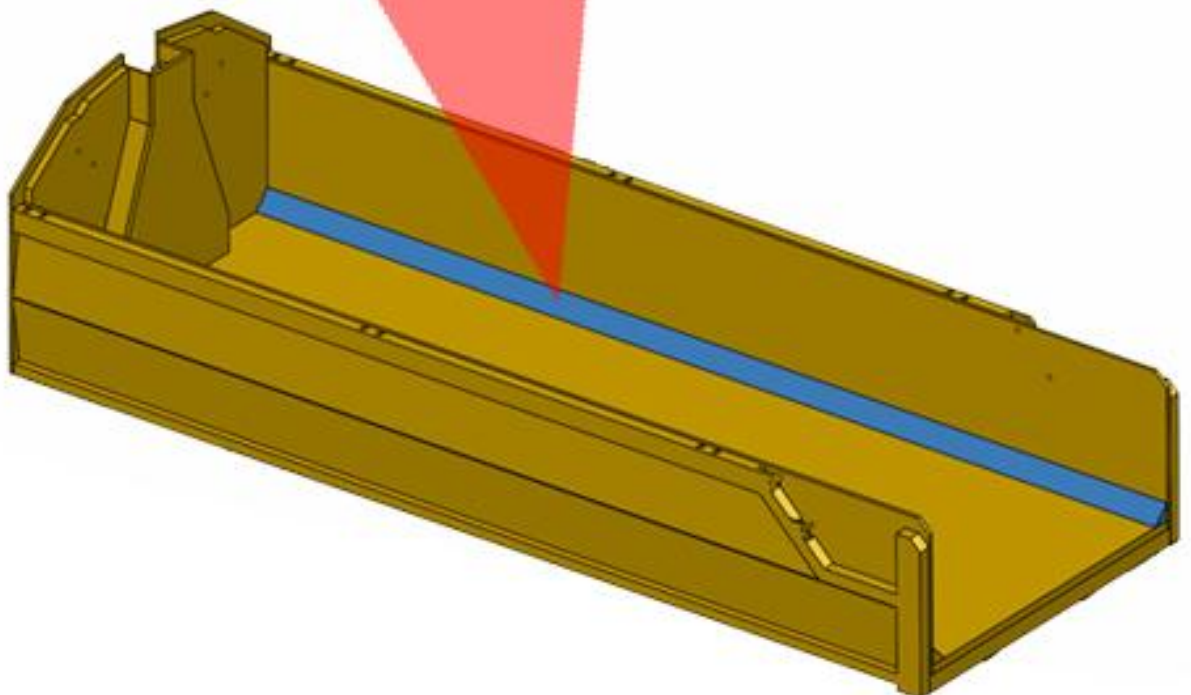

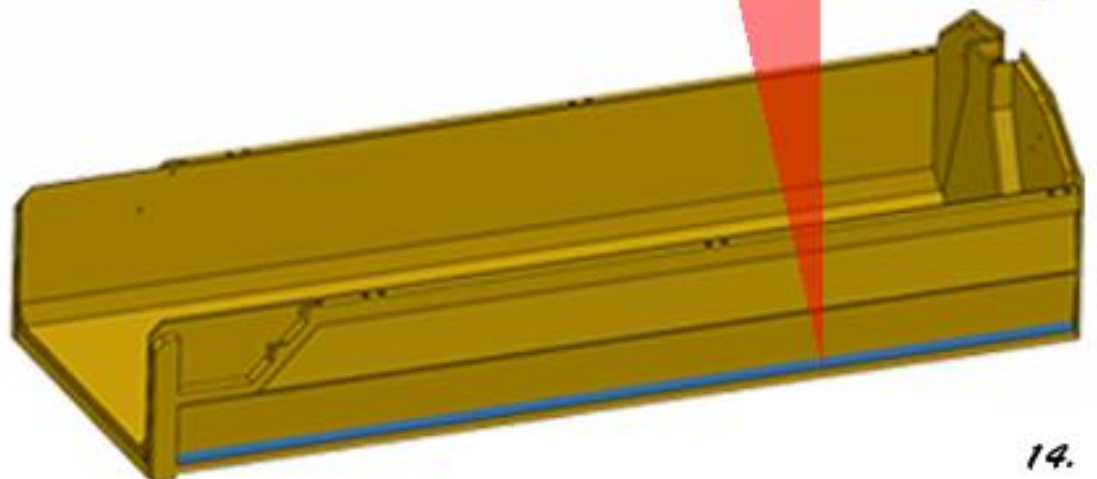
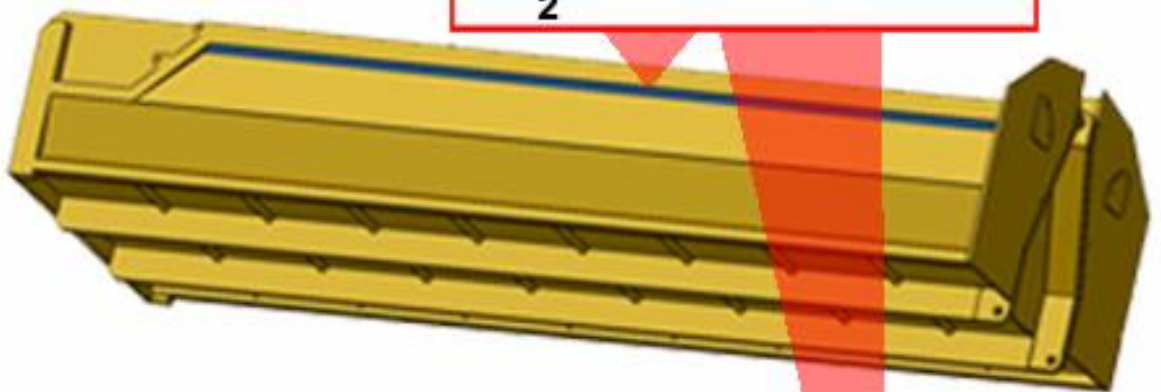
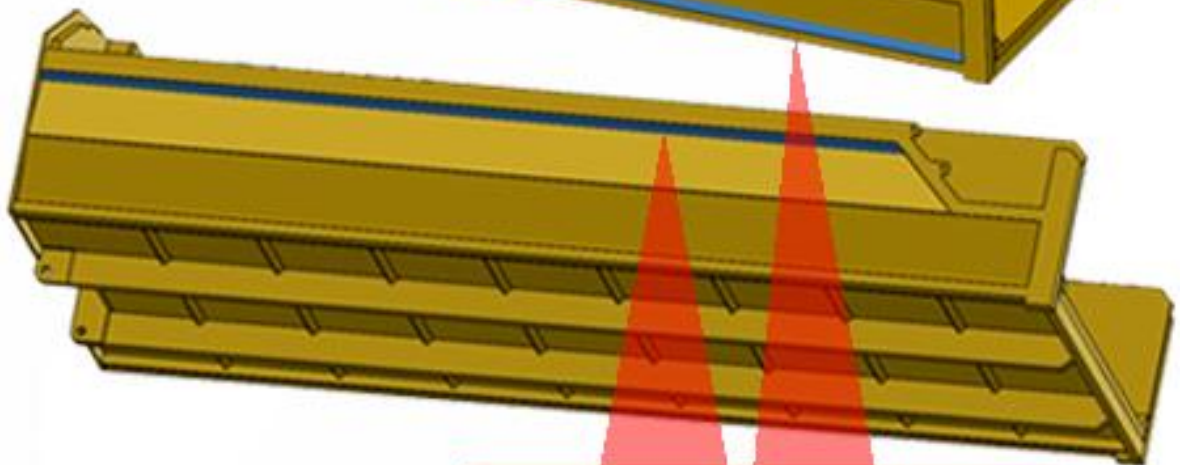
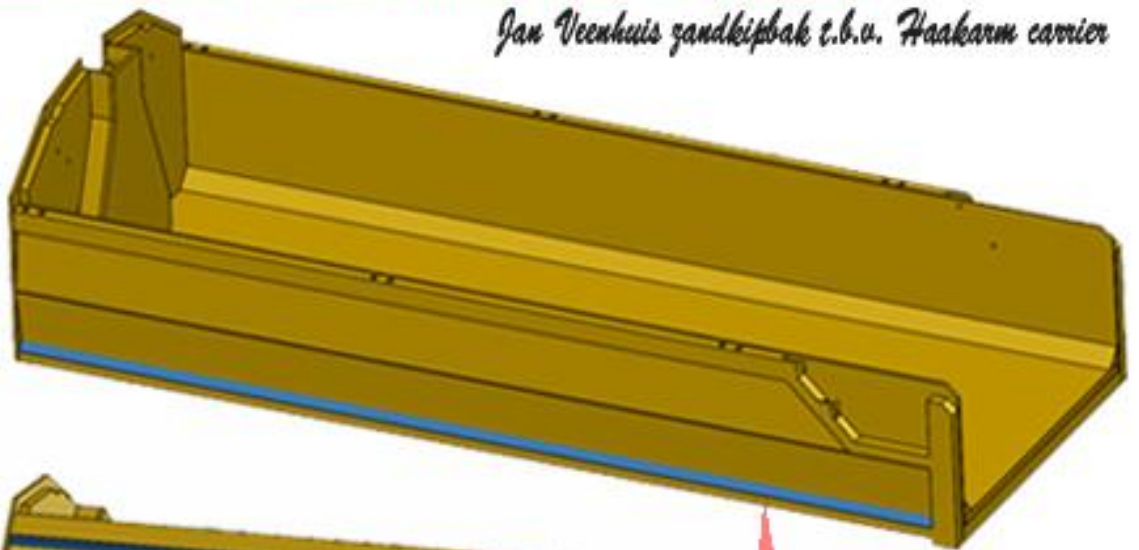

Jan Veenhuis Silagebak t.b.v. 3 assen Haakarm nr. 40125

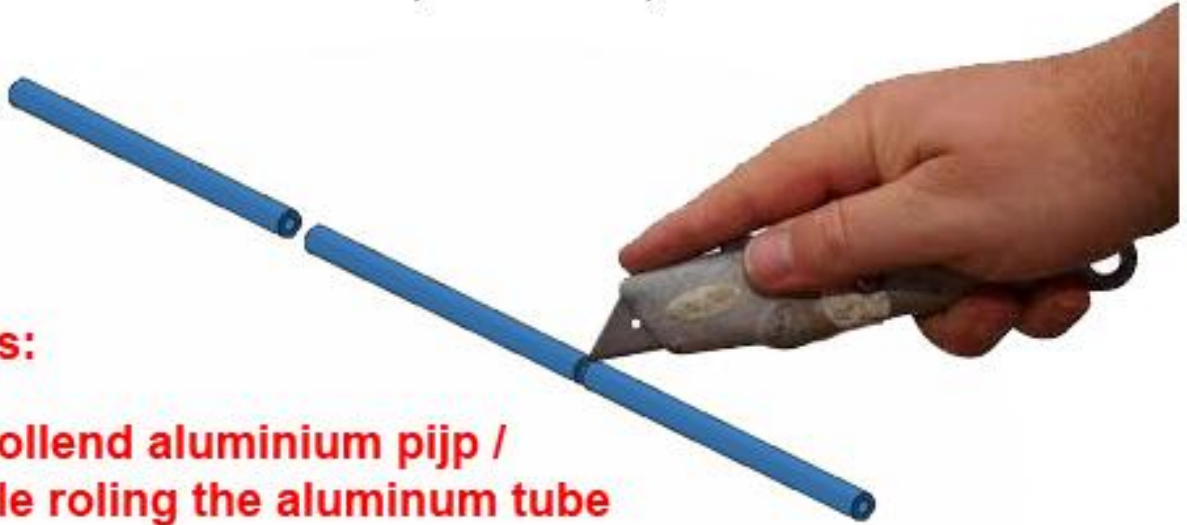

**Cilinders:**

**Snij al rollend aluminium pijp /  
Cut while rolling the aluminum tube**

**39:** Aluminium pijp / pipe **A**

Ø 2 mm buitenmaat / outside

x

1 Ø mm binnenmaat / inside

x

Lengte / lengths 20.5 mm

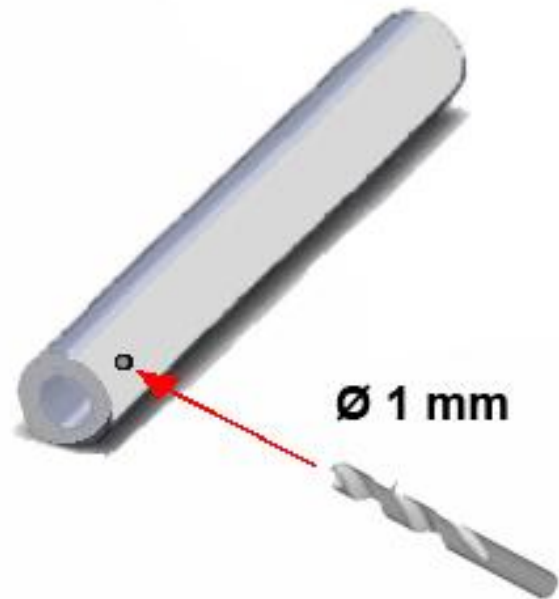

**40:** Aluminium pijp / pipe **B**

Ø 1 mm buitenmaat / outside

x

Lengte / lengths 35 mm



Jan Veenhuis Silagebak t.b.v. 3 assen Haakarm nr. 40125

41:

Aluminium pijp / pipe **B**

Ø 1 mm buitenmaat / outside  
x  
Lengte / lengths +/- 35mm

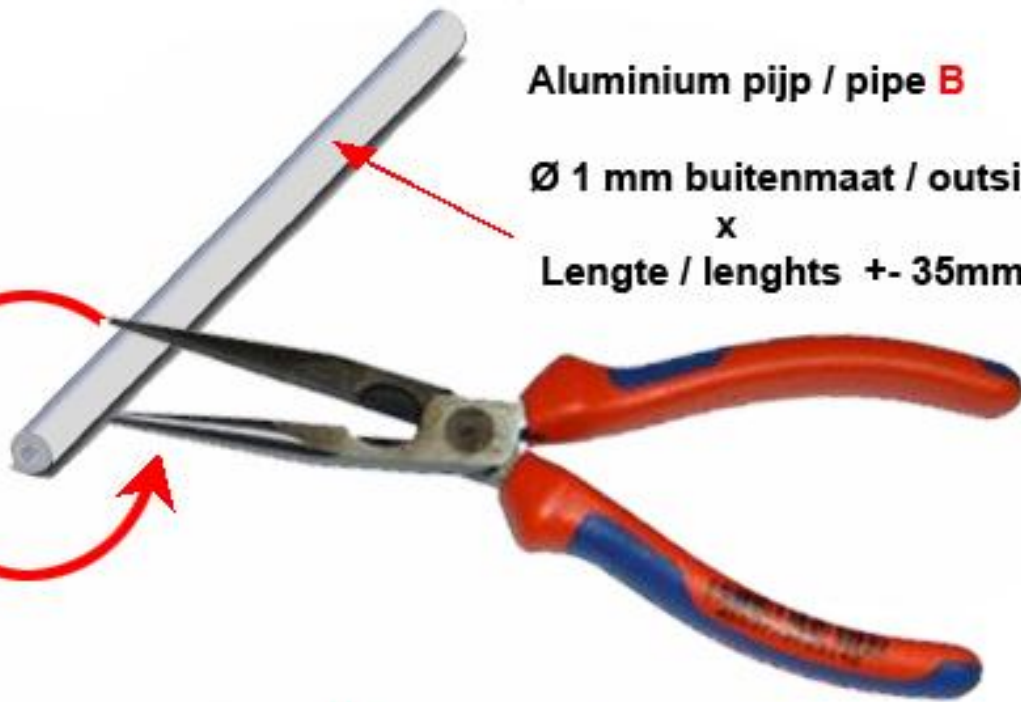

Aluminium pijp / pipe **B**

Lengte / lengths 23.5 mm

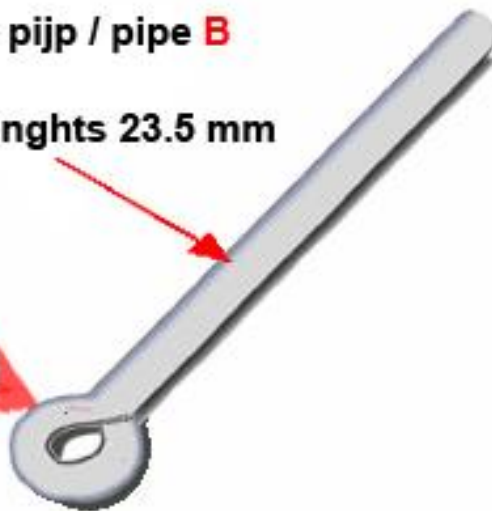

Aluminium pijp / pipe **A**

Aluminium pijp / pipe **B**

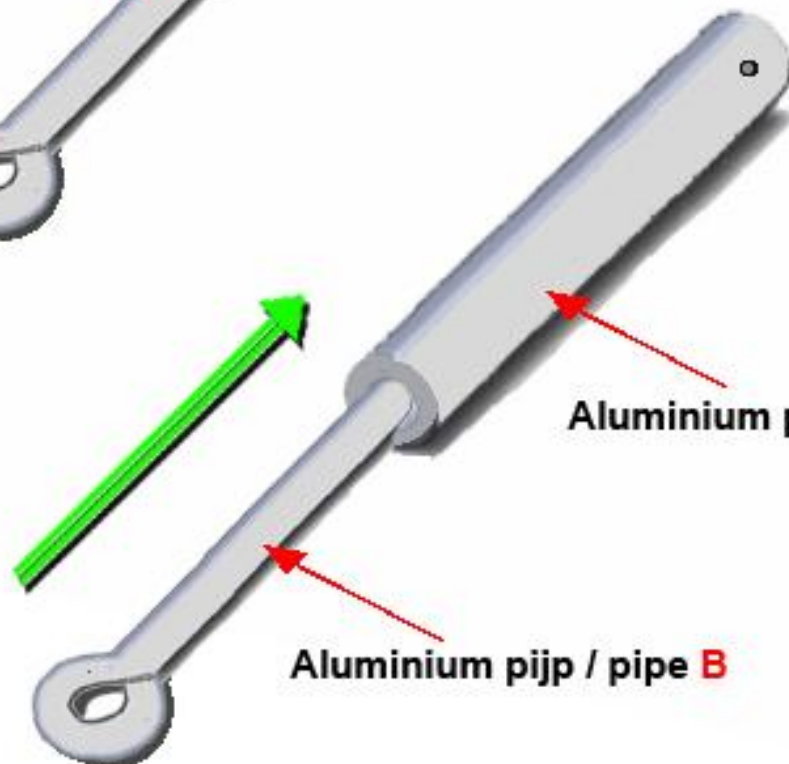





42.

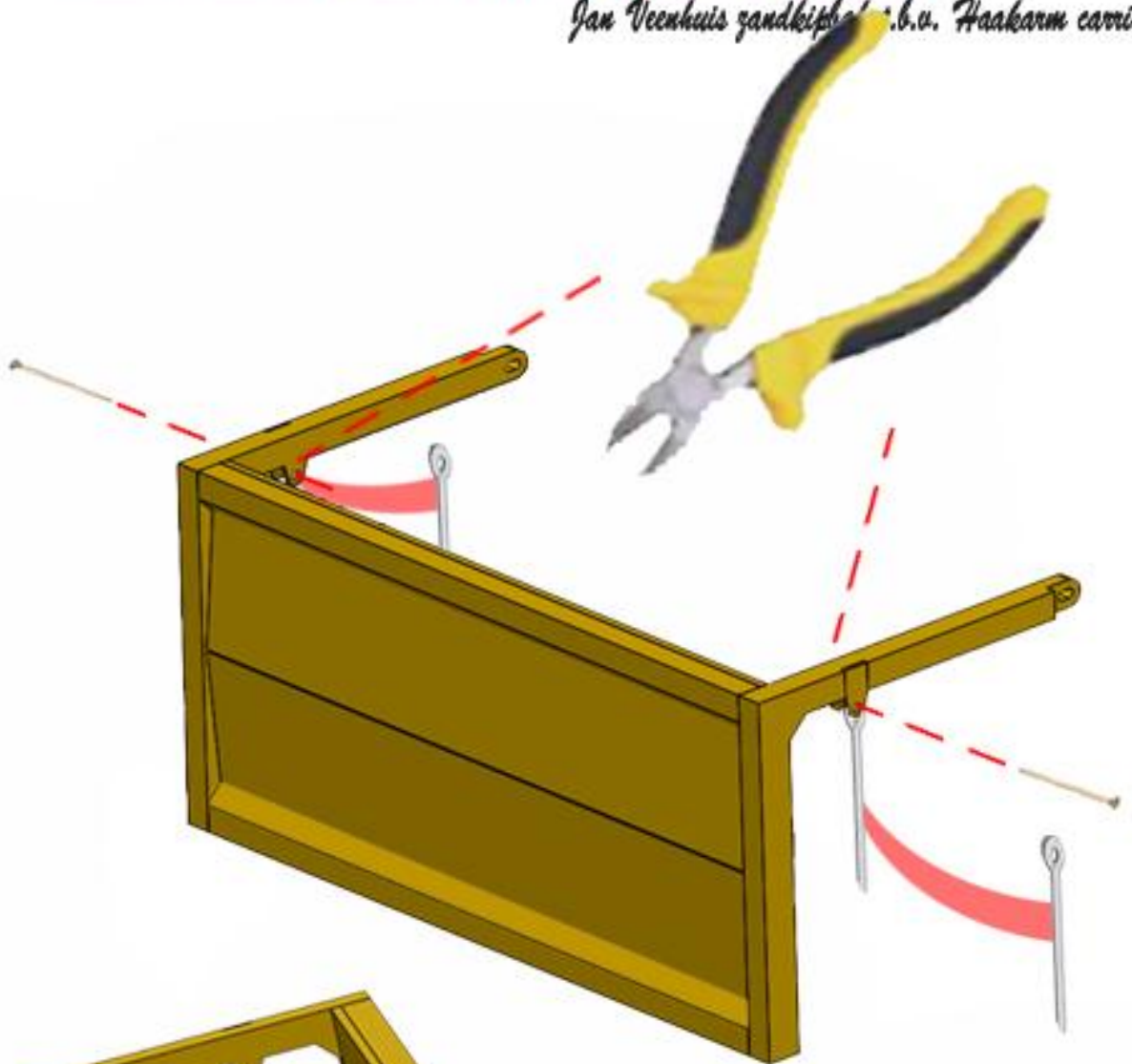

43:

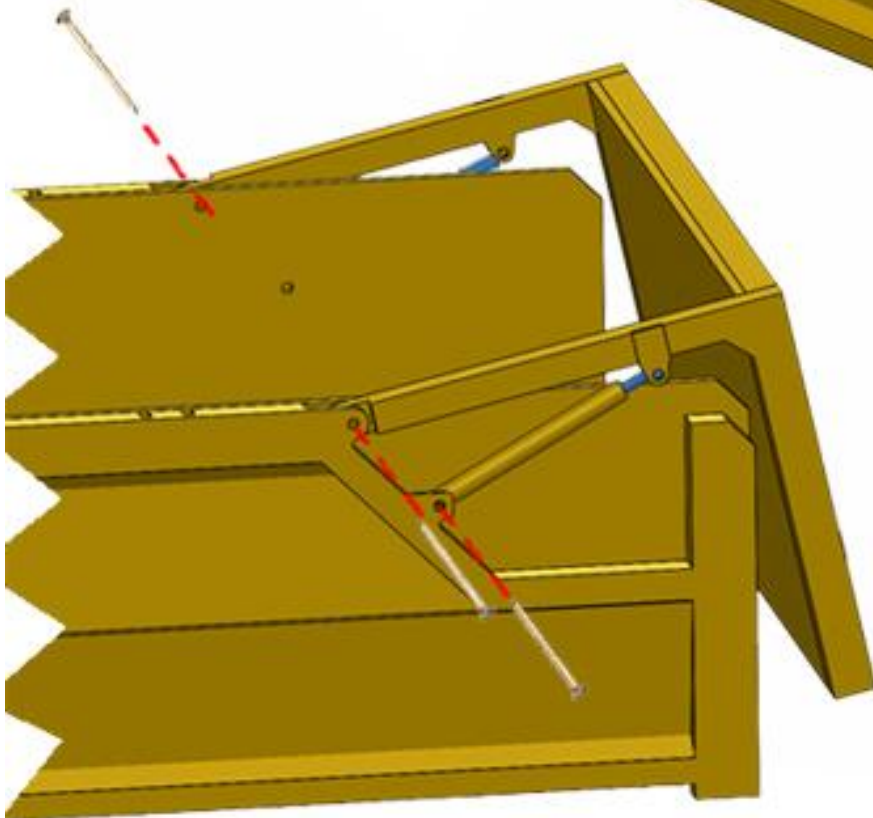

44.

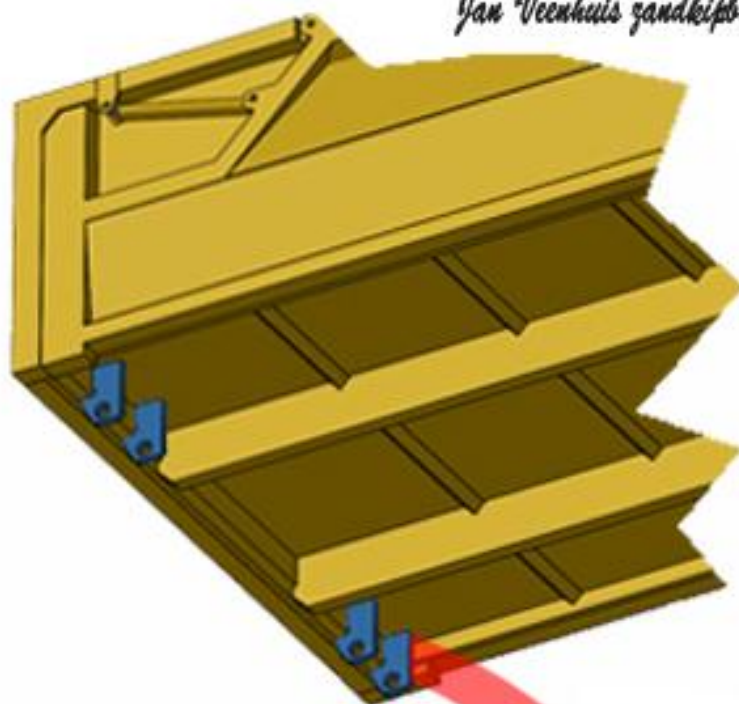

Aluminium buis / pipe  
Ø 2 mm uitwendig / outside

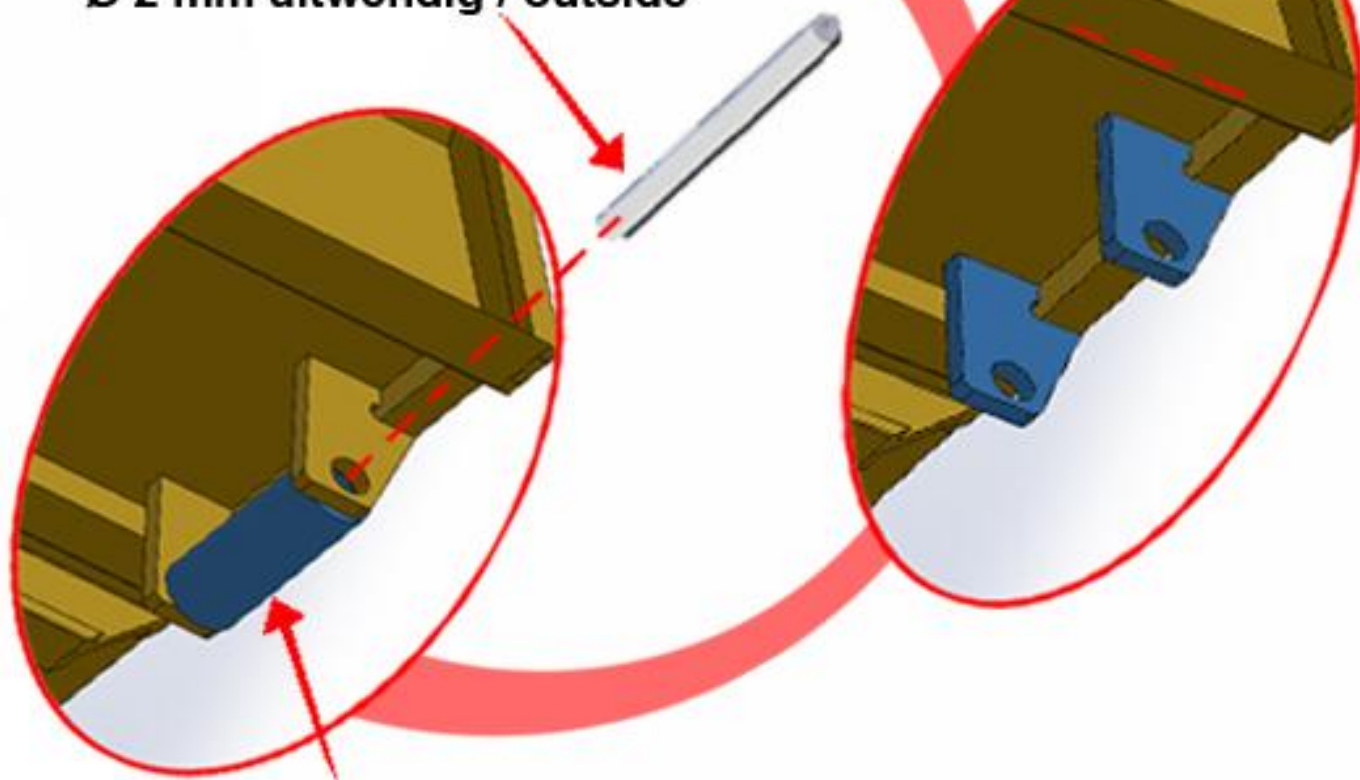

Polystyreen pijp / pipe  
Ø 4 mm uitwendig / outside  
Ø 2 mm Inwendig / Inside  
Lengte / Length 10-12 mm



# Farmmodels.nl

Landbouwmachines - Onderdelen - Bouwlijnen - Stokers - Bioruimtes



*Jan Veenhuis zandkipbak t.b.v. Haakarm carrier*

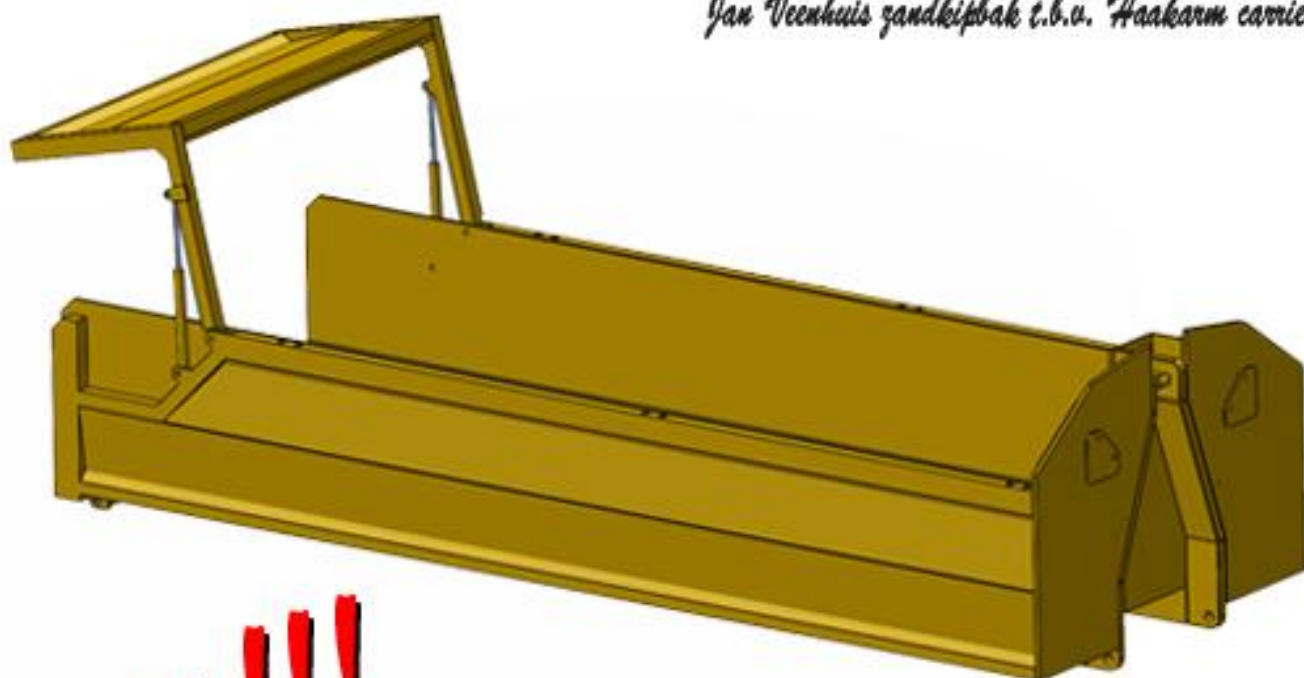

**Klaar !!!**  
**Ready !!**

